

Installation Instruction Sheet

for Pipe Cover Assembly, P/N 415-53902-00

Table 1: Parts List

ITEM	DESCRIPTION	QTY	BWC Part Number
1	PIPE COVER BRACKET	1	239-53905-00
2	LEFT SIDE WALL	1	239-53906-00
3	RIGHT SIDE WALL	1	239-53907-00
4	PIPE COVER BASE	1	239-53908-00
5	PIPE COVER FRONT DOOR	1	239-53909-00
6	#10-12 X 3/4" HEX SCREW WITH WASHER	6	239-52581-00
7	#8-18 x 1/2" Screw	2	239-32761-00

Step 1: Take the bracket (item 1) and attach it to the bottom bracket used by the water heater by using two of the (item 6) screws. The outer holes are recommended as shown.

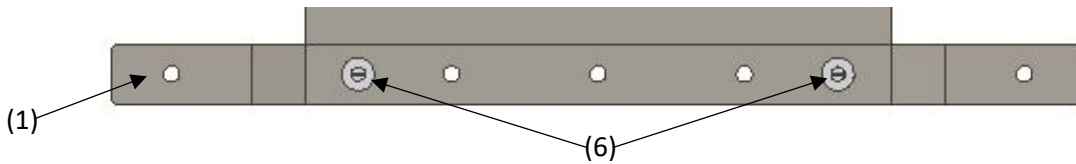

Step 2: Attach both side walls (items 2 & 3) to the outer holes of the bracket using 1 (item 6) screw for each wall.

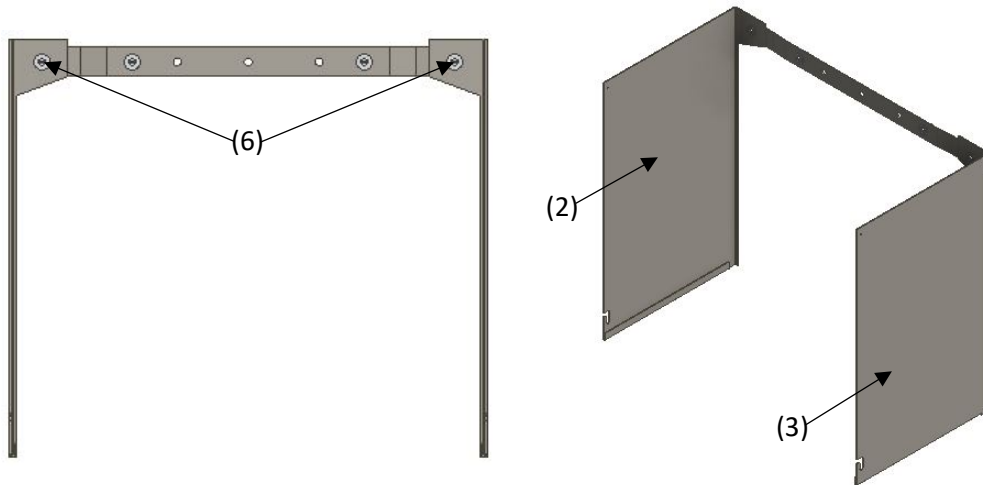

Step 3: Slide the base (item 4) into the grooves on the bottom of the side walls. Then use the last two (item 6) screws and attach the base to the wall using the holes shown (make sure that the condensate pipe goes through the hole in the base).

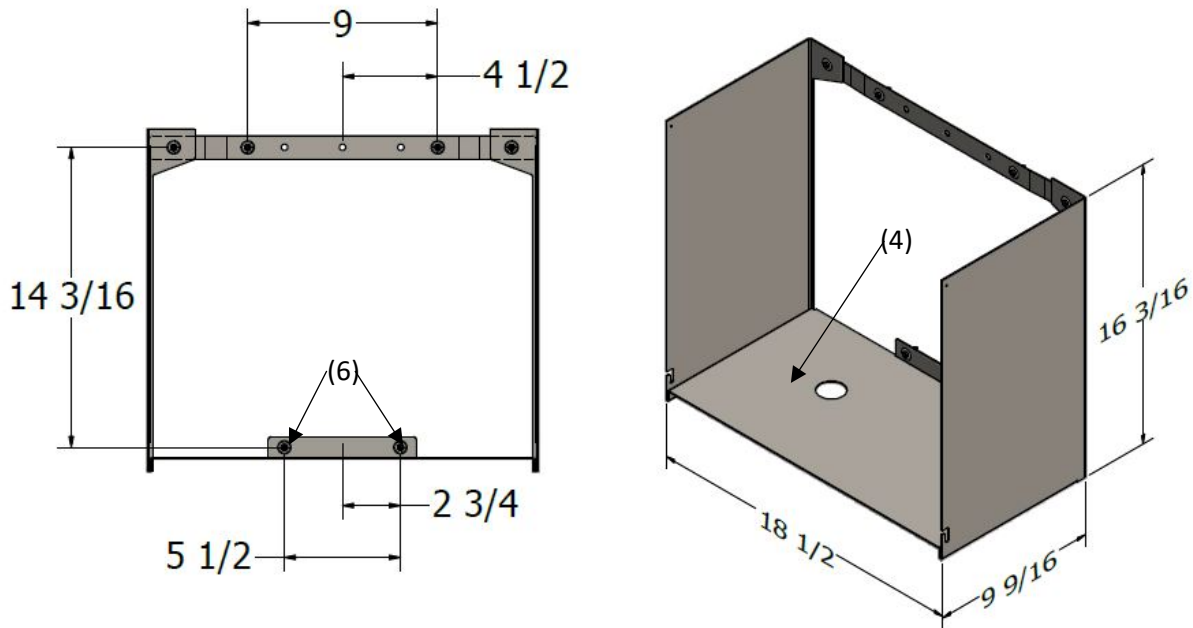

Step 4: Attach the front door (item 5) to the sides by sliding the pins into the slots located in the side walls. Then rotate the door up while making sure that the walls are in between the supports welded to the door. Finish attaching the door by screwing the two (item 7) screws through the pilot holes located in the door and side walls.

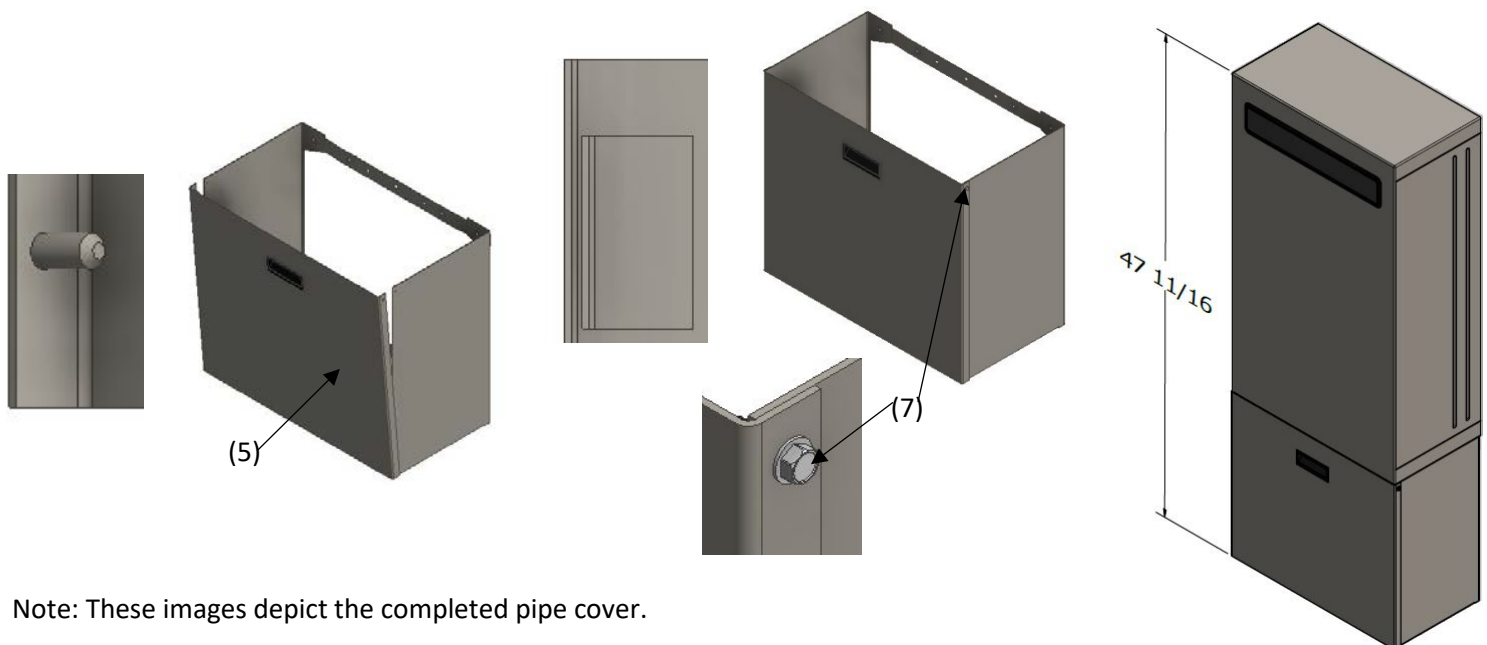

Note: These images depict the completed pipe cover.