

SUPPLEMENT TO INSTRUCTION MANUAL
P/N 238-51000-00 & 238-51011-00
Replaces pg. 27 (238-51000-00) or
pg. 28 (238-51011-00) in instruction manual.)

Wiring Diagram

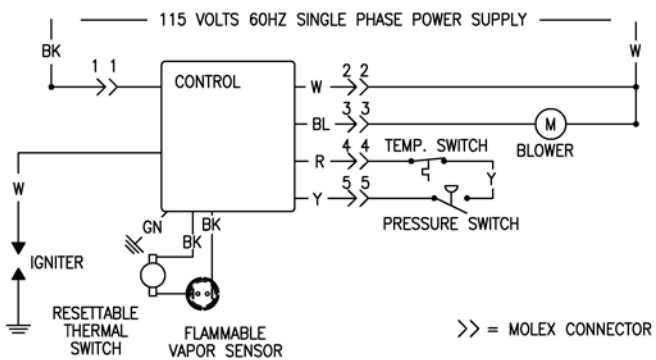
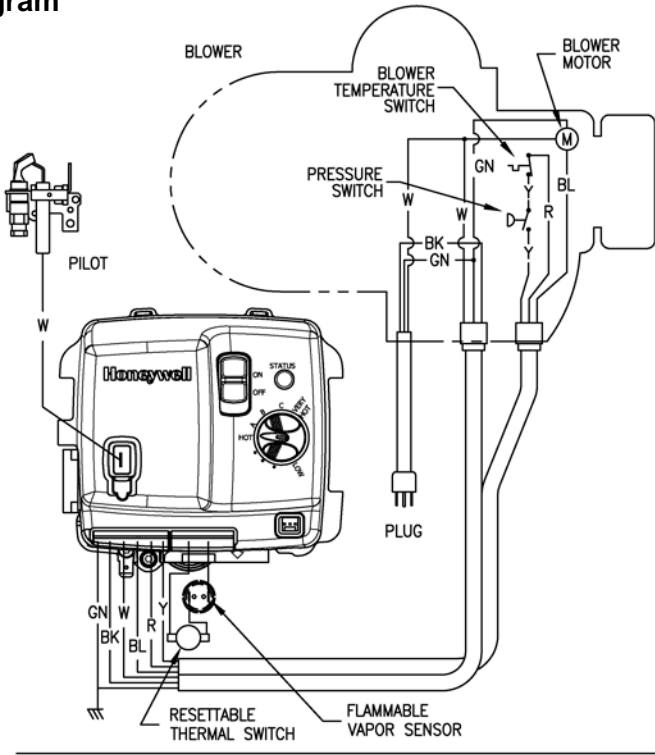

ELECTRICAL RATING			
115 VOLTS	60HZ	LESS THAN 12 AMPS	

IF ANY OF THE ORIGINAL WIRES SUPPLIED WITH THE APPLIANCE MUST BE REPLACED, IT MUST BE REPLACED WITH APPLIANCE WIRE MATERIAL WITH A MINIMUM TEMPERATURE RATING OF 105°C AND A MINIMUM SIZE OF NO. 18 AWG.

Figure 10 or Figure 6

Burner Flame Check
(Replaces pg. 31 (238-51000-00) or
pg. 32 (238-51011-00) in instruction manual.)

These models are equipped with self adjusting air mixture and do not have an adjustable air shutter (See *Figure 12*). At periodic intervals a visual check of the main burner and pilot flames should be made to determine if they are burning properly. The main burner flame should light smoothly from the pilot.

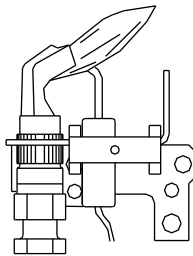
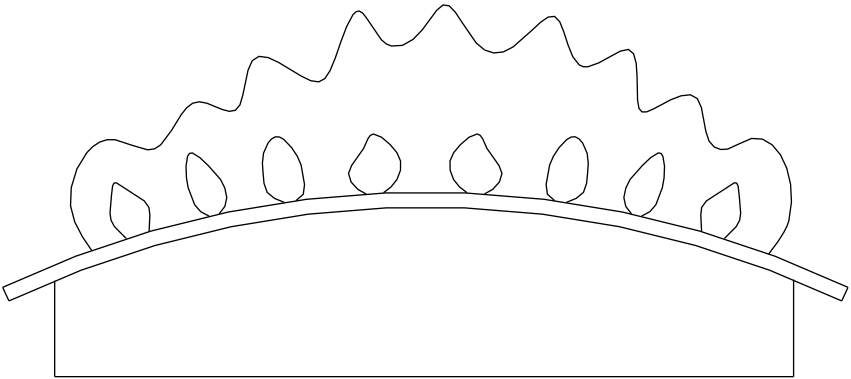

PILOT IN OPERATION

Figure 12 or Figure 8

(Replaces pg. 38 (238-51000-00) or
pg. 39 (238-51011-00) in instruction manual.)

Troubleshooting continued-

<u>Fault</u>	<u>Probable Cause</u>
Resettable thermal switch tripped (open)	1. Burner failure. 2. Flammable vapor present.

Control Sequence of Operation

Start up Sequence

Upon powering up, the control checks for the presence of the vapor sensor, if the resistance is in the expected range the control will begin normal operation after 5 to 8 seconds.

Normal Heating Sequence

1. The thermostat senses a need for heat.
2. The control checks the pressure switch condition.
3. If the pressure switch is open, the control sends power to the blower motor.
4. The blower starts moving combustion air through the combustion system.
5. The pressure switch closes.
6. The control senses the closed pressure switch and starts the ignition process by providing a spark at the pilot electrode and allowing gas to flow to the pilot.
7. When the pilot is lit the gas control senses the pilot flame and opens the main gas valve.
8. The main burner is lit.
9. The main burner and blower continue to operate until the thermostat is satisfied.
10. When the thermostat is satisfied the main and pilot gas valves close.
11. The blower operates for a short post purge period before shutting down.
12. The water heater remains in the stand-by mode until the next call for heat.

(Replaces pg. 39 (238-51000-00) or
pg. 40 (238-51011-00) in instruction manual.)

PARTS LIST DRAWING

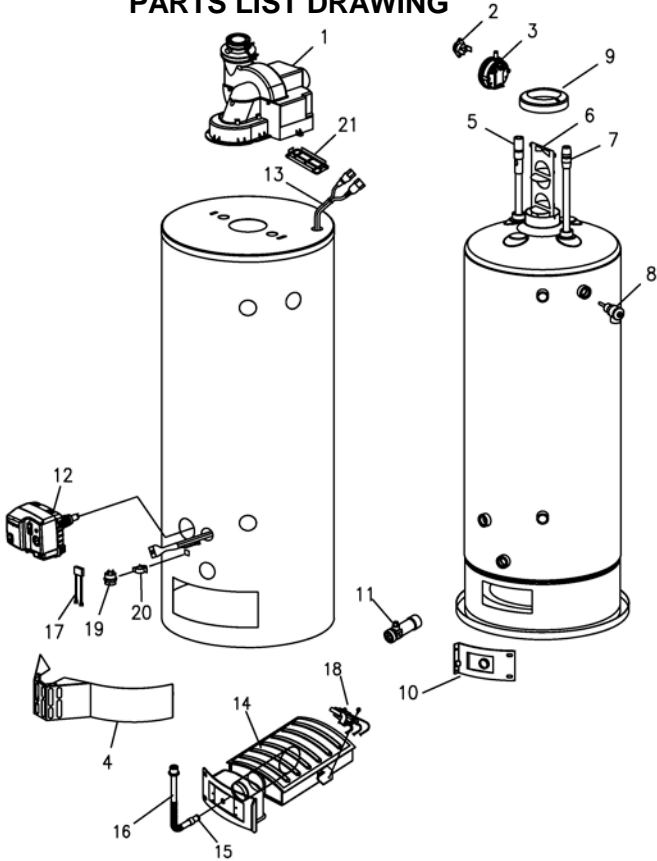

PARTS LIST (Continued)

PART NAME AND DESCRIPTION	
1. Blower Assembly	12. Gas Valve
2. Temperature Switch	13. Wire Harness
3. Pressure Switch	14. Radiant Burner
4. Outer Door	15. Orifice
5. Mag. Anode- Hot Water Outlet	16. Gas Feedline to Burner
6. Flue Baffle Assembly	17. Sensor Harness
7. Dip Tube-Cold Water Inlet	18. Pilot Assembly
8. Temp. & Pressure Relief Valve	19. Flammable Vapor Sensor
9. Flue Reducer	20. Flam. Vapor Sensor Clip
10. Inner Door Assembly	21. Dilution Air Clip
11. Drain Valve	

(Replaces pg. 40 (238-51000-00) or
pg. 41 (238-51011-00) in instruction manual.)

**THE FOLLOWING INSTRUCTIONS ARE FOR INSTALLATION OF:
GAS WATER HEATERS SUITABLE FOR WATER (POTABLE)
HEATING AND SPACE HEATING**

1. All piping components connected to this water heater for space heating applications must be suitable for use with potable water. In Massachusetts, space heating piping length **must not** exceed 50 feet (*15.24 meters*).
2. Toxic chemicals, such as those used for boiler treatment, **must not** be introduced into potable water used for space heating.
3. This water heater **must not** be connected to an existing heating system or component(s) previously used with a non-potable water heating appliance.
4. When the system requires water for space heating at temperatures higher than required for other uses, a means such as an ASSE approved mixing valve shall be installed to temper the water for those uses in order to reduce scald hazard potential.

Please refer to the illustrations on the following pages for the suggested piping arrangements.

Suggested piping arrangement (Continued)

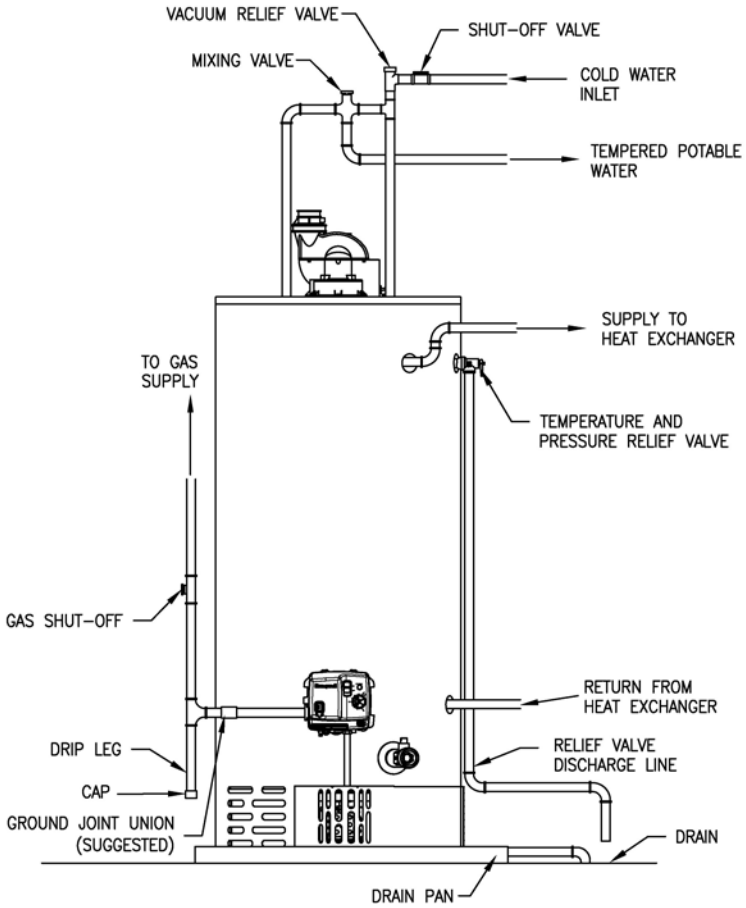

Suggested piping arrangement (Continued)

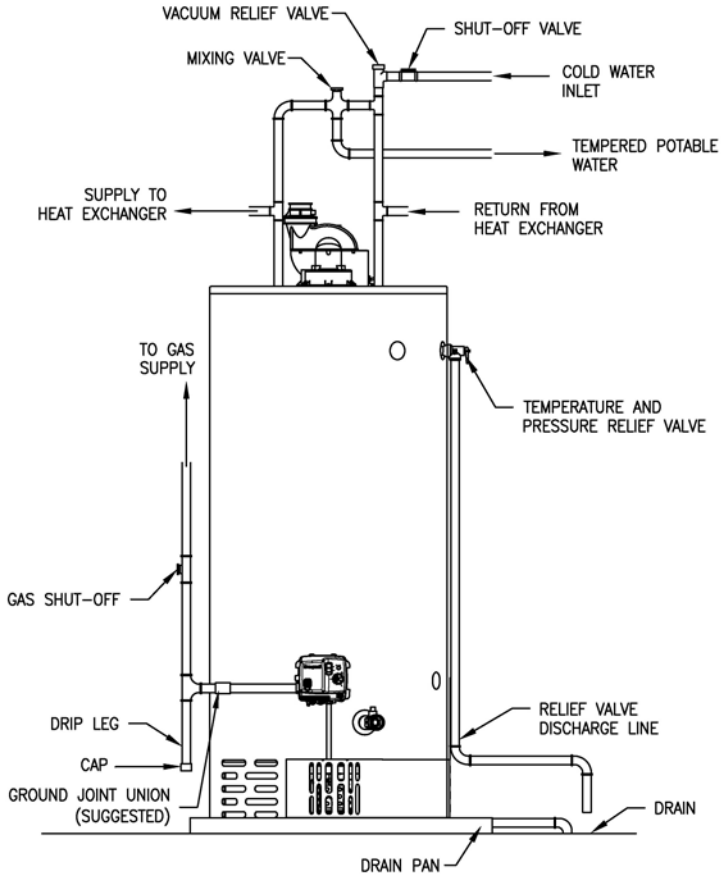

Notes