

The FT Series, floor standing, condensing boiler is configured for Natural Gas (NG) from the factory. A Propane Conversion Kit is included with every FT. The gas conversion kit will show you how to convert your FT boiler to propane gas. If your FT does not have the bag containing the conversion kit, a replacement kit can be obtained. Contact the manufacturer and request a replacement conversion kit.



NOTICE

If your installation altitude is greater than 2000ft, check that the “High Altitude” Installer setting has been adjusted to suit your installation altitude. See sections 4.13 and 4.14 in the FT series Boiler Installation and Operation Instructions Manual.

WARNING

This gas conversion kit shall be installed by a qualified service agency in accordance with the manufacturer’s instructions and all applicable codes and requirements of the authority having jurisdiction. The information in these instructions must be followed to minimize the risk of fire or explosion or to prevent property damage, personal injury or death. The qualified service agency is responsible for the proper installation of this kit. The installations is not proper and complete until the operation the converted appliance is checked as specified in the manufacturer’s instructions supplied with the kit. Installation must conform to local codes and the latest edition of the National Fuel Gas Code, ANSI Z223.1 and CAN-B149.1. Failure to follow instructions could result in serious injury or property damage. The qualified agency performing this work assumes responsibility for gas conversion.

CAUTION

This Combi or Heat Only has already been set to burn natural gas, but can be converted to burn LP gas. Before placing the Combi or Heat Only boiler into operation, verify that the proper type of gas is supplied to your combination boiler.

Steps 1 thru 12

1. Open 2 toggle latch clamps fixed to the upper case of the product. Remove the front door from the product by lifting it upwards while tilting it by about 30°.
2. Turn OFF the FT. The ON / OFF button is located behind the front cover on the left front side of the appliance.
3. Turn OFF the GAS and WATER supply to the FT (valves are located on the plumbing pipes.)
4. Locate the Gas Inlet Pipe at the top left of the unit as shown in Figure A, and loosen the Brass Fittings at both ends of the Gas Inlet Pipe. See Figure B.
5. Completely unthread the brass fitting on the blower end of the Gas Inlet Pipe and then carefully swing the Gas Inlet Pipe to the left or right, just enough so that it is out of the way. See Figure B.
6. Remove the existing natural gas nozzle or orifice. Note that the flat side of the orifice is towards the blower. Save the packing for re-use. See Figure C.

Model	Natural Gas (NG) part #	Propane Gas (LP) part #	Orifice
FTCF199 and FTHF199	FT1780 (8.3 mm)	FT1802 (6.35 mm)	

Table A Gas Conversion Parts

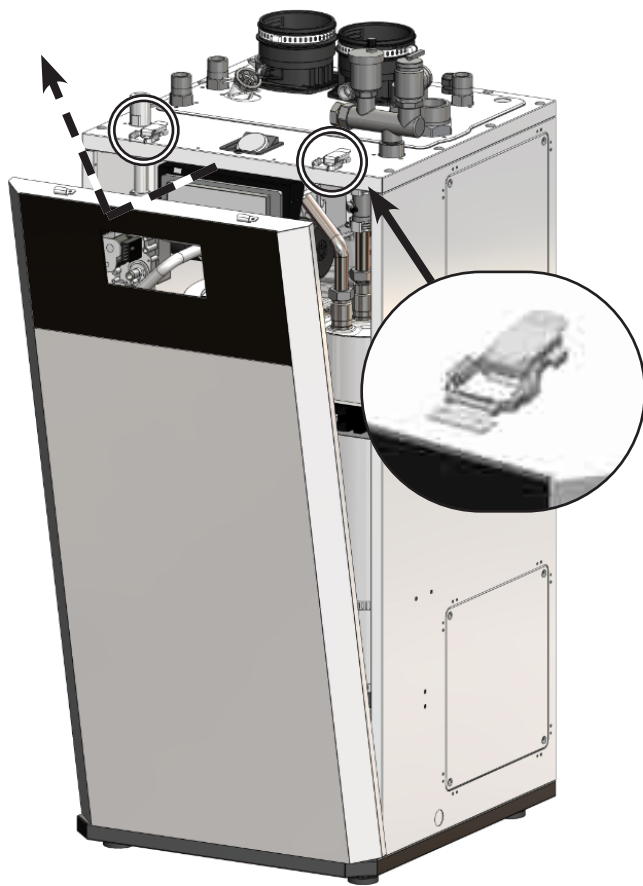

Figure A

Figure B

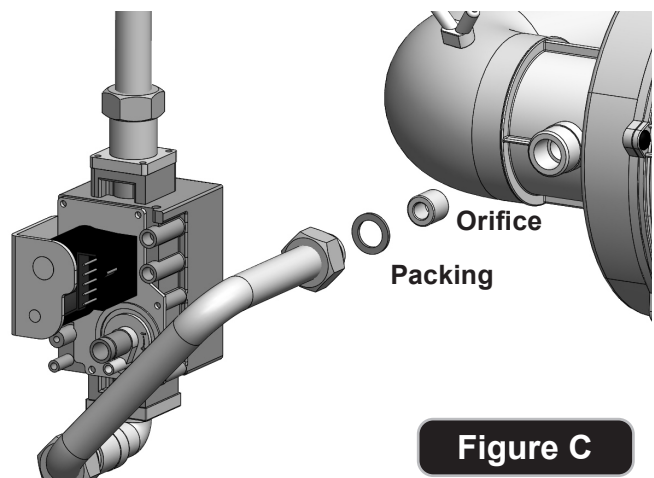
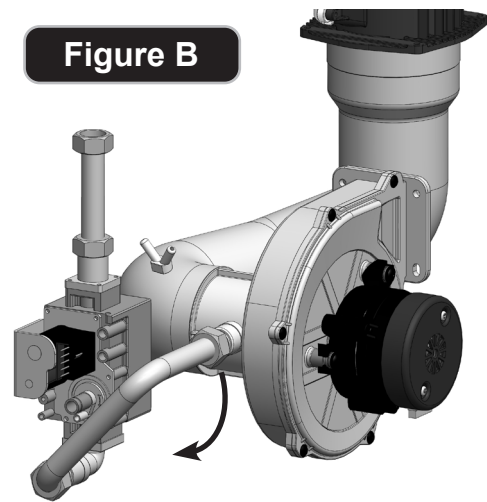

Figure C

This conversion shall be installed by a qualified service agency in accordance with the manufacturer's instructions and all applicable codes and requirements of the authority having jurisdiction. If the information in these instructions is not followed exactly, a fire, an explosion or production of carbon monoxide may result causing property damage, personal injury or loss of life. The qualified service agency is responsible for the proper and complete installation of this kit. The installation is not proper and complete until the operation of the converted appliance is checked as specified in the manufacturer's instruction supplied with the kit. Installation must conform to local codes and the latest edition of the National Fuel Gas Code, ANSI Z223.1 and CAN-B149.1. Failure to follow instructions could result in serious injury or property damage. The qualified agency performing this work assumes responsibility for gas conversion.



Ce conversion doit être installé par un organisme de service conformément aux instructions du fabricant et tous les codes et les exigences de l'autorité compétente. Si les informations contenues dans ces instructions n'est pas suivi à la lettre, un incendie, une explosion ou de la production de monoxyde de carbone mais résultat causant des dommages matériels, des blessures ou des pertes de vie. Le service est responsable pour la bonne et complète l'installation de ce kit. L'installation n'est pas correcte et complète jusqu'à ce que le fonctionnement de l'appareil converti est vérifiée comme spécifié dans le manuel d'instruction fourni avec le kit. L'installation doit être conforme aux codes locaux et la dernière édition du National Code de gaz combustible, ANSI Z223.1 et peut-B149.1. Non-respect des instructions peut entraîner des blessures graves ou des dommages matériels. L'organisme qualifié effectuant ce travail suppose la responsabilité de conversion au gaz.

Note: Please pay close attention to the orientation of the PCB board and relative switch positions. (Actual installed PCB board is rotated 90 clockwise from shown position).

DIP Switch		State
1	199,000 BTU	ON
2		ON
3		ON
4	Vent size 3"	ON
	Vent size 2"	OFF
5	NG Gas Type	ON
	LP Gas Type	OFF
6	Max	6: ON / 7: OFF
7	Min	6: OFF / 7: ON
6, 7	Nominal	6: OFF / 7: OFF

Table B DIP Switch Settings

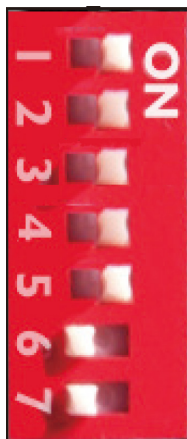

Shown is a Model 199 with 3" Venting and using Natural Gas

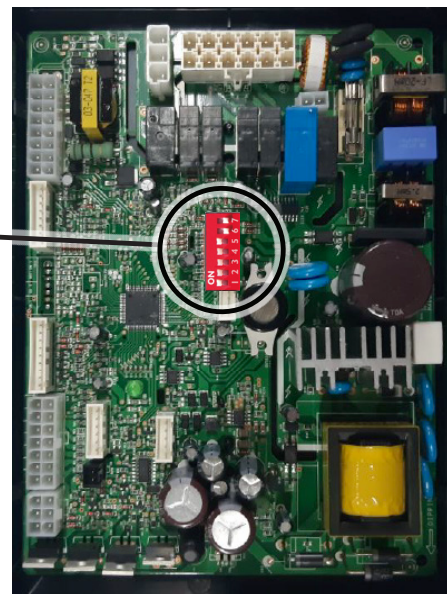

Figure D

7. Install the new LP (propane) orifice. Re-use the existing gasket.
8. Return the Gas Inlet Pipe to its original position and tighten both brass fittings.
9. Per Table B, set DIP Switch 5 to OFF for LP Propane.
10. Turn ON the GAS and WATER supply to the FT
11. Now start the unit and adjust combustion as described in Section 4.13.
12. Upon completion of set up, write in the correct Conversion Date and the Technicians Name to the included gas conversion sticker. See Figure F. Then apply that sticker adjacent to the rating plate.

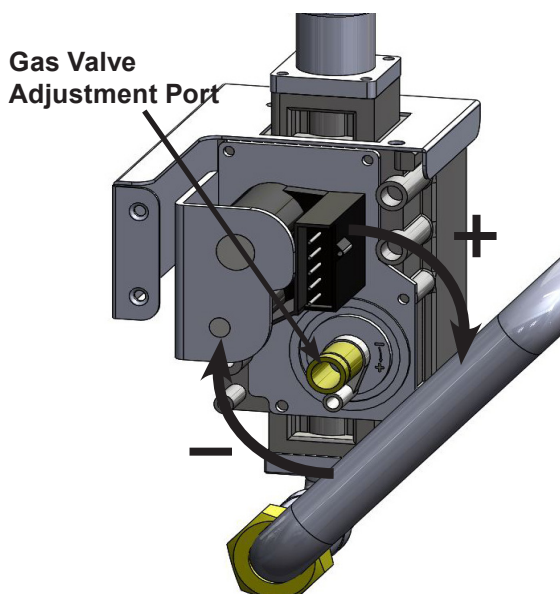

Figure E

NOTE: Installer is required to verify combustion settings as part of the installation process. CO should not exceed 200 ppm.

CO ₂ value		Natural Gas (NG)		Propane Gas (LP)	
		2" VENT	3" VENT	2" VENT	3" VENT
FTCF199 and FTHF199 (and all altitudes)	MAX FIRE	8.5 - 10.5%		9.5 - 11%	
	MIN FIRE	8 - 10%		9 - 10.5 %	

Manifold Pressure		Natural Gas (NG)		Propane Gas (LP)	
		2" VENT	3" VENT	2" VENT	3" VENT
FTCF199 and FTHF199	MAX FIRE	-0.129"WC	-0.314"WC	-0.169"WC	-0.173"WC
	MIN FIRE	-0.015"WC	-0.015"WC	-0.015"WC	-0.015"WC

NOTE: Values in the range of -.001 to -.35 Inches WC are indicative of proper set-up. If your values are outside this range, call technical support.

This boiler was converted on ___/___/___/ to ___ gas with Kit No. _____ by _____ (name and address of organization making this conversion, who accepts the responsibility for the correctness of this field conversion)."
 « Cette chaudière a été convertie le (___/___/___) pour fonctionner au gaz ___ à l'aide de la trousse n° par (nom et adresse de l'organisme qui a effectué la conversion), qui accepte l'entière responsabilité de la qualité de la conversion. »

Figure F (Conversion label)