

Commander Series[®] Atmospheric Vent Commercial Gas Water Heater



Photo is of
UCG-100H-199-3N

FEATURING:



The Commander Series[®] Models feature:

- **ICON HD[®]**—Intelligent proven design combines temperature control, diagnostic codes, and system ignition functions into a single control board with a digital LCD display.
 - **Operation Mode**—Two different digitally displayed operation modes have the capability of adjusting the temperature setting up to 180°F (82°C), and adjusting the degree setting (°F to °C, or °C to °F).
 - **Service Mode**—Eight different digitally displayed service modes can be easily cycled through by pressing the select button.
 - Adjust the temperature setting up to 180°F (82°C).
 - Change the degree setting (°F to °C, or °C to °F).
 - Lock the maximum temperature setting that can be adjusted in operation mode.
 - Display the average water temperature (for two sensor models) and see the upper and lower temperature sensor readings.
 - Read the flame current of the pilot flame.
 - Show diagnostic codes - 16 different numeric error codes; access an error code history of the last 10 codes.
- **BMS Integration**—Via Modbus standard, BACnet[®] compatible via gateway kit.
- **Optional Air Intake Ducting**—Optional ducting of PVC, CPVC, or ABS air intake. Can either be installed as a traditional atmospheric product requiring inside air for combustion or applications where outside air is preferred.
- **Premix Power Burner**—A self compensating negative pressure system automatically regulates fuel flow when a change in combustion air is detected. This provides for optimum combustion and efficiency. Automatically adjusts for altitudes up to 10,000 ft (3048m).
- **Direct Spark Ignition**—For improved operational dependability and durability.
- **Integrated Exhaust System**—New configuration and vent connector height allow for easy replacement of existing atmospheric vent water heaters.
- **Sanitizing Capability**—Complies with sanitation capabilities up to 180°F (82°C).
- **Factory-Installed Hydrojet[®] Total Performance System**—Sediment reducing device that also increases first hour delivery of hot water while minimizing temperature build-up in tank.
- **Vitraglas[®] Lining**—An exclusively engineered enamel formula that provides superior tank protection from the highly corrosive effects of hot water. This formula (Vitraglas[®]) is fused to the steel surface by firing at a temperature of over 1600°F (871°C).
- **Insulation System**—Non-CFC foam covers the sides and top of the tank, reducing heat loss. This results in less energy consumption, improved efficiencies, and jacket rigidity.
- **Water Connections**—Factory-installed true dielectric fittings extend water heater life and simplify water line connections.
- **1" (25mm) NPT Side Connections for Space Heating.**
- **Up to 82% Thermal Efficiency.**
- **Zero Inch Clearance to Combustibles** Excluding UCG-80H-399 & UCG-100H-399.
- **Hand Hole Cleanout.**
- **NSF Construction Available.**
- **T&P Relief Valve**—Installed.
- **Low Restrictive Brass Drain Valve**—Durable tamper proof design.
- **Ultra Low NOx Construction (14 ng/J NOx or natural gas and 77 ppm NOx limit for liquid propane).**
- **CSA Certified Low Lead Content.**
- **ASME Code Available on All Models.**

3 or 5-Year Limited Tank Warranties / 1-Year Limited Warranty on Component Parts.

For more information on warranty, please visit www.bradfordwhite.com
For products installed in USA, Canada, and Puerto Rico. Some states do not allow limitations on warranties. See complete copy of the warranty included with the heater.



Commander Series® Atmospheric Vent Commercial Gas Water Heater

Commander Series® Models

Meet or exceed ASHRAE 90.1b (current standard) C.E.C. Listed
Up to 82% Thermal Efficiency

NATURAL AND LIQUID PROPANE GAS

Model Number	Nominal Gal. Capacity		Input BTU/Hr.	GPH Recovery at Degree Rise*			A Floor to Flue Conn. in.	B Jacket Dia. in.	C Vent Size in.	D Floor to T&P Conn. in.	E Floor to Gas Conn. in.	F Floor to Top of Heater in.	G Floor to Cold Water Conn./Hot Water Conn. in.	H Depth in.	K Floor to Cold Water Conn. in.	L Floor to Hot Water Conn. in.	M Water Conn. NPT in.	S Gas Conn. Size in.	Relief Valve Open in.	Approx. Shipping Weight lbs.
	U.S. Gal.	Imp. Gal.		40°F	100°F	140°F														
UCG-80H-125-3N(A)	80	67	125,000	308	123	88	63 3/8	28	5	43 15/16	54 3/8	52 3/16	54 3/4	32	9 9/16	46 15/16	1 1/2	1/2	3/4	535
UCG-80H-199-3N(A)	80	67	199,999	493	197	141	63 3/8	28	6	43 15/16	54 3/8	52 3/16	54 3/4	32	9 9/16	46 15/16	1 1/2	1/2	3/4	535
UCG-80H-270-3N(A)	80	67	270,000	665	266	190	63 3/8	28	6	43 15/16	54 3/8	52 3/16	54 3/4	32	9 9/16	46 15/16	1 1/2	1/2	1	545
UCG-80H-399-3N(A)	80	67	399,999	960	384	274	63 3/8	28	8	43 15/16	54 3/8	52 3/16	54 3/4	32	9 9/16	46 15/16	1 1/2	1/2	1	545
UCG-100H-199-3N(A)	100	83	199,999	493	197	141	73 1/4	28	6	52 3/8	62 7/8	60 11/16	63 3/4	29 5/8	9 13/16	53 7/8	1 1/2	1/2	3/4	632
UCG-100H-270-3N(A)	100	83	270,000	665	266	190	73 1/4	28	6	52 3/8	62 7/8	60 11/16	63 3/4	29 5/8	9 13/16	53 7/8	1 1/2	1/2	1	632
UCG-100H-399-3N(A)	98	82	399,999	994	398	284	77 7/16	28	8	52 3/8	62 7/8	60 11/16	63 3/4	29 5/8	9 13/16	53 7/8	1 1/2	1/2	1	657

Model Number	Nominal Liter Capacity	Input kW	LPH Recovery at Degree Rise*			A Floor to Flue Conn. mm.	B Jacket Dia. mm.	C Vent Size mm.	D Floor to T&P Conn. mm.	E Floor to Gas Conn. mm.	F Floor to Top of Heater mm.	G Floor to Cold Water Conn./Hot Water Conn. mm.	H Depth mm.	K Floor to Cold Water Conn. mm.	L Floor to Hot Water Conn. mm.	M Water Conn. NPT mm.	S Gas Conn. Size mm.	Relief Valve Open mm.	Approx. Shipping Weight kgs.
			22°C	56°C	78°C														
UCG-80H-125-3N(A)	303	36.6	1164	466	333	1610	711	127	1116	1381	1326	1391	813	233	1192	38	13	19	243
UCG-80H-199-3N(A)	303	58.6	1864	746	533	1610	711	152	1116	1381	1326	1391	813	233	1192	38	13	19	243
UCG-80H-270-3N(A)	303	79.1	2517	1007	719	1610	711	152	1116	1381	1326	1391	813	233	1192	38	13	25	247
UCG-80H-399-3N(A)	303	117.2	3634	1454	1038	1610	711	203	1116	1381	1326	1391	813	233	1192	38	13	25	247
UCG-100H-199-3N(A)	379	58.6	1866	745	533	1835	711	152	1330	1597	1541	1607	752	249	1368	38	13	19	286
UCG-100H-270-3N(A)	379	79.1	2517	1006	719	1835	711	152	1330	1597	1541	1607	752	249	1368	38	13	25	286
UCG-100H-399-3N(A)	371	117.2	3757	1476	1060	1967	711	203	1330	1597	1541	1607	752	249	1368	38	13	25	298

For Propane Gas models change suffix "N" to "X". Example: UCG-100H-199-3X (UCG-100H-399 available in Natural Gas only). All models comply with the latest Ultra Low NOx requirements (14 ng/J or less for natural gas and 77 ppm NOx limit for liquid propane).

Amp Draw range = 1.0 to 1.8 amps.

(A) ASME - All models are available with ASME construction.

To order ASME construction add the (A) to the end of the model number.

* Based on manufacturer's rated recovery efficiency.

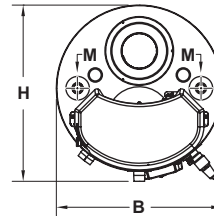
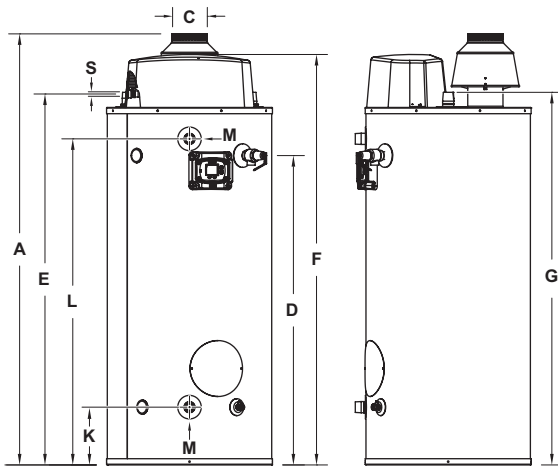

Optional Air Intake Ducting Maximum Lengths

Model	2" PVC, ABS, or CPVC	3" PVC, ABS, or CPVC	4" PVC, ABS, or CPVC
UCG-80H-125-3(N,X)	20 ft.	50 ft.	75 ft.
UCG-80H-199-3(N,X)	20 ft.	50 ft.	75 ft.
UCG-100H-199-3(N,X)	20 ft.	50 ft.	75 ft.
UCG-80H-270-3(N,X)	20 ft.	50 ft.	75 ft.
UCG-100H-270-3(N,X)	20 ft.	50 ft.	75 ft.
UCG-80H-399-3(N,X)	N/A	25 ft.	50 ft.
UCG-100H-399-3N	N/A	25 ft.	50 ft.

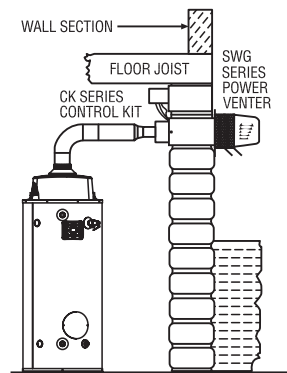

TYPICAL APPLICATIONS

Optional Power Vent Kits – for side wall termination only.

Model Numbers	Kit Number
UCG-80H-125/199/270,	239-81764-00
UCG-100H-199/270:	
UCG-80H-399,	239-81766-00
UCG-100H-399:	



Vent Kit

BACnet® Gateway Kit Number – 415-53943-00.

Optional Honeywell EnviraCOM™ Alarm Module – Provides indication (contacts are closed) when an alarm is present via normally open contacts (rated for up to 24 VAC). Kit Number – 265-51961-00.

Sample Specification

The water heater shall be a Bradford White model UCG-____ with a rated storage capacity of not less than ____ gallons/ liters, a minimum gas input of _____ BTU/Hr., a minimum recovery of ____ GPH/LPH at 100°F (56°C) temperature rise, a Thermal Efficiency Rating of _____. It shall be design certified by CSA International (formerly AGA and CGA) for 180°F (82°C) application, either with or without a separate storage tank. The tank shall be lined with Vitraglas® vitreous enamel and shall have a bolted hand hole cleanout. This water heater shall be equipped with stainless steel cold water inlet, Hydrojet® Sediment Reduction System. The heater shall be insulated with Non-CFC foam. This water heater shall be equipped with an ICON HD® ignition system, an ASME rated T&P relief valve and a premix combustion system. The water heater shall be factory assembled and tested. A digital LCD display shall be integrated into the front and be an adjustable electronic thermostat to any temperature up to 180°F. A recycling Energy Cut Off (E.C.O.) shuts off all gas in the event of an overheat condition. The entire installation shall be made in compliance with state and local codes and ordinances.

General

All gas water heaters are certified at 300 PSI test pressure (2068 kPa) and 150 PSI working pressure (1034 kPa). All models are design certified by CSA International (formerly AGA/CGA), to ANSI standard Z-21.10.3, for up to 180°F (82°C) application as an Automatic Storage Heater. As an Automatic Storage Heater, all models are complete, self-contained water heating systems. It needs no separate storage tank, pump, wiring or elaborate piping network. When equipped with a mixing valve, it can supply 180°F (82°C) sanitizing and lower temperature general purpose hot water simultaneously. These models can be used either as a single unit or in multiples connected in series or parallel (recommended).

Dimensions and specifications subject to change without notice in accordance with our policy of continuous product improvement.

— BRADFORD WHITE IS —



Sales: 800-523-2931 ■ Fax 215-641-1612

24/7 Technical Support: 800-334-3393 ■ Email techserv@bradfordwhite.com

Built to be the Best®