



COMMERCIAL GAS REPLACEMENT PARTS LIST

Ultra Low NOx Atmospheric Vent Water Heater



UCG100H(199,270,399)3(N,X)
UCG80H(125,199,270,399)3(N,X)

Includes Hydrojet®
Total Performance System

Effective: November, 2019
ECO 8308

NOTE: BOTH MODEL AND SERIAL
NUMBERS ARE REQUIRED FOR
ORDERING REPLACEMENT PARTS

Dimensions and specifications
subject to change without notice.



As required by the state of California Proposition 65.

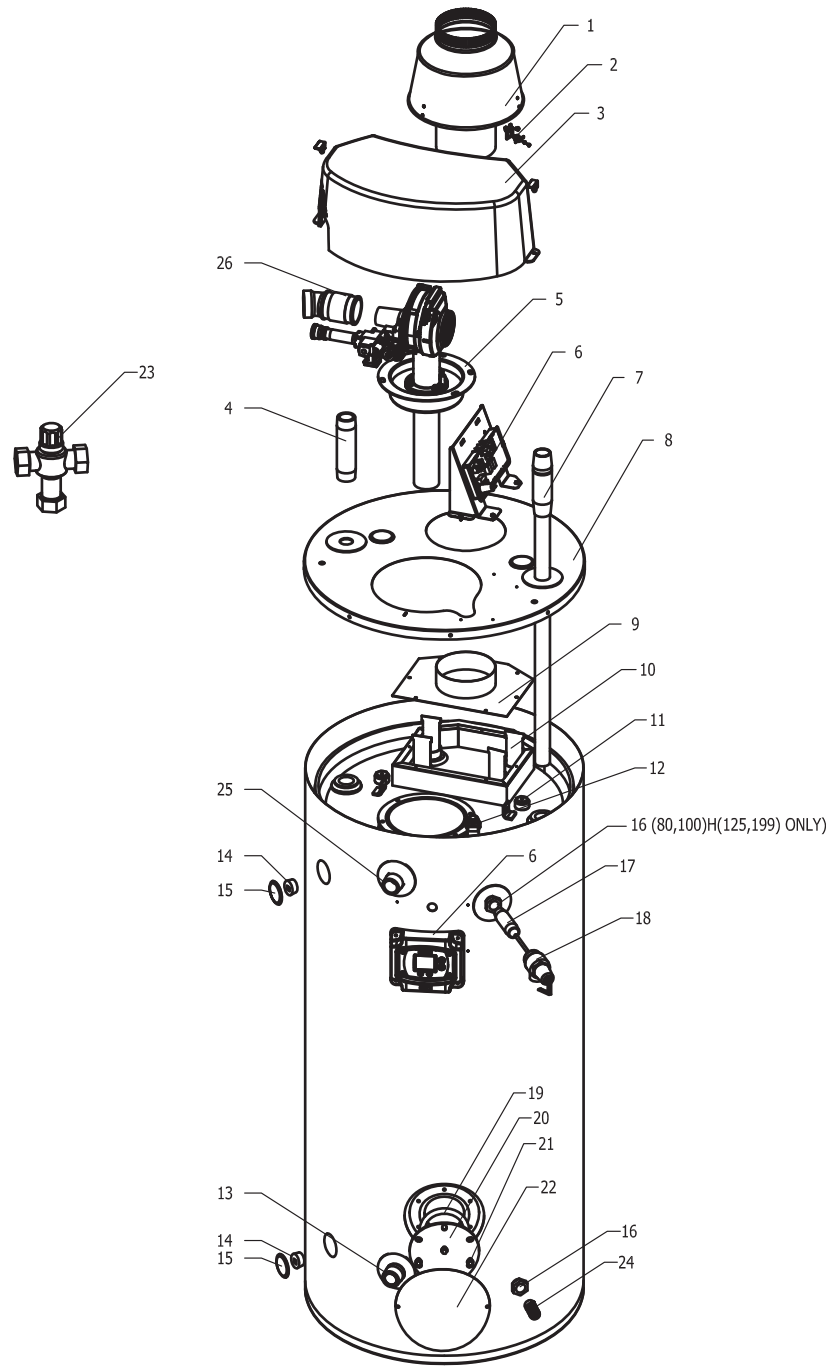

Item	Description	Model	Model	Model	Model
		UCG100H1993N	UCG100H1993X	UCG100H2703N	UCG100H2703X
1	Draft Diverter	239-49610-01	239-49610-01	239-49610-01	239-49610-01
2	Assembly Blocked Vent Switch	239-49622-00	239-49622-00	239-49622-00	239-49622-00
3	Surround with Latches	239-50510-00	239-50510-00	239-50510-00	239-50510-00
4	Nipple Hot Water Outlet Plasticsert (Top Connection)	229-40913-01	229-40913-01	229-40913-01	229-40913-01
5	Combustion System Assembly	243-50529-01	243-50529-02	243-50529-03	243-50529-04
6A	Control Panel Assembly (Prior to Serial # PL40538368)	(see page 8)	(see page 8)	(see page 8)	(see page 8)
6B	Control Panel Assembly (Serial # PL40538368 And After)	(see page 18)	(see page 18)	(see page 18)	(see page 18)
7	Inlet Tube Hydrojet (Top Connection)	229-46709-02	229-46709-02	229-46709-02	229-46709-02
8	Jacket Head	239-51297-01	239-51297-01	239-51297-01	239-51297-01
9	Exhaust Collector Cover	239-50530-01	239-50530-01	239-50530-01	239-50530-01
10	Baffle 2" Flue (4 Req'd)	239-50512-02	239-50512-02	239-50512-03	239-50512-03
11	Anode (Magnesium) (up to 3 req'd)	224-47782-07	224-47782-07	224-47782-07	224-47782-07
	Anode (Aluminum) (up to 3 req'd)	224-38508-10	224-38508-10	224-38508-10	224-38508-10
	Anode (Aluminum A420) (up to 3 req'd)#	224-49559-04	224-49559-04	224-49559-04	224-49559-04
12	Well Sensor	233-46558-03	233-46558-03	233-46558-03	233-46558-03
13	Inlet Tube Hydrojet (Front Connection)	229-44375-00	229-44375-00	229-44375-00	229-44375-00
14	Plug (2 Req'd)	239-02048-00	239-02048-00	239-02048-00	239-02048-00
15	Hole Closure (4 Req'd)	239-31547-02	239-31547-02	239-31547-02	239-31547-02
16	1" to 3/4" Bushing (2 Req'd for 199kBTUH, 1 Req'd for 270kBTUH models)	239-02052-00	239-02052-00	239-02052-00	239-02052-00
17	T&P Nipple	229-32762-02	229-32762-02	239-50053-02	239-50053-02
18	T&P Valve	230-30246-00	230-30246-00	230-33630-04	230-33630-04
19	Cleanout Gasket	205-18427-00	205-18427-00	205-18427-00	205-18427-00
20	Cleanout Cover	205-18428-00	205-18428-00	205-18428-00	205-18428-00
21	Screw 5/16 - 18 x 1/2 (6 req'd)	239-82166-00	239-82166-00	239-82166-00	239-82166-00
22	Clean Out Cover Access	243-20299-00	243-20299-00	243-20299-00	243-20299-00
23	Mixing Device	239-51778-00	239-51778-00	239-51778-00	239-51778-00
24	Drain Valve Brass (No Handle)	265-42351-02	265-42351-02	265-42351-02	265-42351-02
25	Nipple Hot Water Outlet Plasticsert (Front Connection)	229-40913-07	229-40913-07	229-40913-07	229-40913-07
26	Vent Terminal	239-50597-00	239-50597-00	239-50597-00	239-50597-00

A420 anode may need to be cut to length.

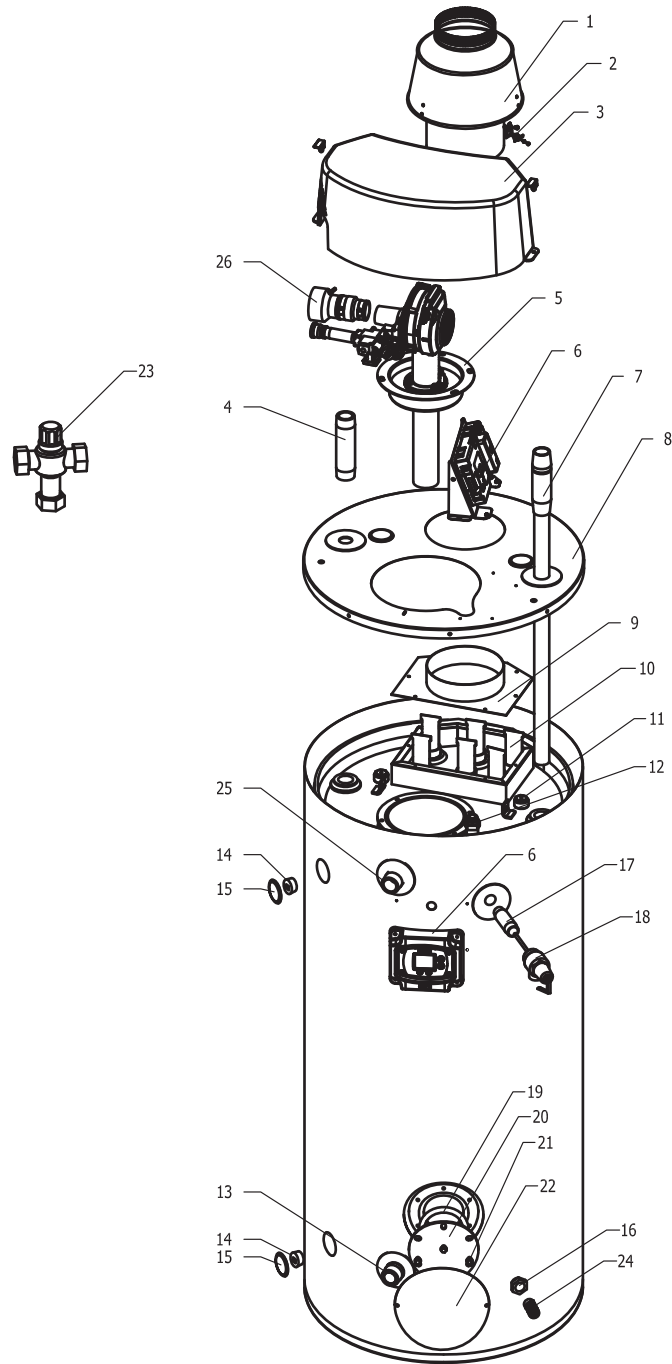

Item	Description	Model UCG80H1253N	Model UCG80H1253X	Model UCG80H1993N	Model UCG80H1993X	Model UCG80H2703N	Model UCG80H2703X
1	Draft Diverter	239-49610-04	239-49610-04	239-49610-01	239-49610-01	239-49610-01	239-49610-01
2	Assembly Blocked Vent Switch	239-49622-00	239-49622-00	239-49622-00	239-49622-00	239-49622-00	239-49622-00
3	Surround with Latches	239-50510-00	239-50510-00	239-50510-00	239-50510-00	239-50510-00	239-50510-00
4	Nipple Hot Water Outlet Plastisert (Top Connection)	229-40913-01	229-40913-01	229-40913-01	229-40913-01	229-40913-01	229-40913-01
5	Combustion System Assembly	243-50529-05	243-50529-06	243-50529-07	243-50529-08	243-50529-09	243-50529-10
6A	Control Panel Assembly (Prior to Serial # PL40538368)	(see page 14)	(see page 14)	(see page 14)	(see page 14)	(see page 14)	(see page 14)
6B	Control Panel Assembly (Serial # PL40538368 And After)	---	---	(see page 18)	(see page 18)	(see page 18)	(see page 18)
7	Inlet Tube Hydrojet (Top Connection)	229-46709-01	229-46709-01	229-46709-01	229-46709-01	229-46709-01	229-46709-01
8	Jacket Head	239-51297-01	239-51297-01	239-51297-01	239-51297-01	239-51297-01	239-51297-01
9	Exhaust Collector Cover	239-50530-04	239-50530-04	239-50530-01	239-50530-01	239-50530-01	239-50530-01
10	Baffle 2" Flue (4 or 6 Req'd)	239-50949-01	239-50949-01	239-50949-02	239-50949-02	239-50949-02	239-50949-02
11	Anode (Magnesium) (up to 3 req'd)	224-47782-05	224-47782-05	224-47782-05	224-47782-05	224-47782-05	224-47782-05
	Anode (Aluminum) (up to 3 req'd)	224-38508-04	224-38508-04	224-38508-04	224-38508-04	224-38508-04	224-38508-04
	Anode (Aluminum A420) (up to 3 req'd)#	224-49559-04	224-49559-04	224-49559-04	224-49559-04	224-49559-04	224-49559-04
12	Well Sensor	233-46558-03	233-46558-03	233-46558-03	233-46558-03	233-46558-03	233-46558-03
13	Inlet Tube Hydrojet (Front Connection)	229-44375-00	229-44375-00	229-44375-00	229-44375-00	229-44375-00	229-44375-00
14	Plug (2 Req'd)	239-02048-00	239-02048-00	239-02048-00	239-02048-00	239-02048-00	239-02048-00
15	Hole Closure (4 Req'd)	239-31547-02	239-31547-02	239-31547-02	239-31547-02	239-31547-02	239-31547-02
16	1" to 3/4" Bushing (2 Req'd, Except 270kBTUH only 1 Req'd)	239-02052-00	239-02052-00	239-02052-00	239-02052-00	239-02052-00	239-02052-00
17	T&P Nipple	229-32762-02	229-32762-02	229-32762-02	229-32762-02	239-50053-02	239-50053-02
18	T&P Valve	230-30246-00	230-30246-00	230-30246-00	230-30246-00	230-33630-04	230-33630-04
19	Cleanout Gasket	205-18427-00	205-18427-00	205-18427-00	205-18427-00	205-18427-00	205-18427-00
20	Cleanout Cover	205-18428-00	205-18428-00	205-18428-00	205-18428-00	205-18428-00	205-18428-00
21	Screw 5/16 - 18 x 1/2 (6 req'd)	239-82166-00	239-82166-00	239-82166-00	239-82166-00	239-82166-00	239-82166-00
22	Clean Out Cover Access	243-20299-00	243-20299-00	243-20299-00	243-20299-00	243-20299-00	243-20299-00
23	Mixing Device	239-51778-00	239-51778-00	239-51778-00	239-51778-00	239-51778-00	239-51778-00
24	Drain Valve Brass (No Handle)	265-42351-02	265-42351-02	265-42351-02	265-42351-02	265-42351-02	265-42351-02
25	Nipple Hot Water Outlet Plastisert (Front Connection)	229-40913-07	229-40913-07	229-40913-07	229-40913-07	229-40913-07	229-40913-07
26	Vent Terminal	239-50597-00	239-50597-00	239-50597-00	239-50597-00	239-50597-00	239-50597-00

A420 anode may need to be cut to length.

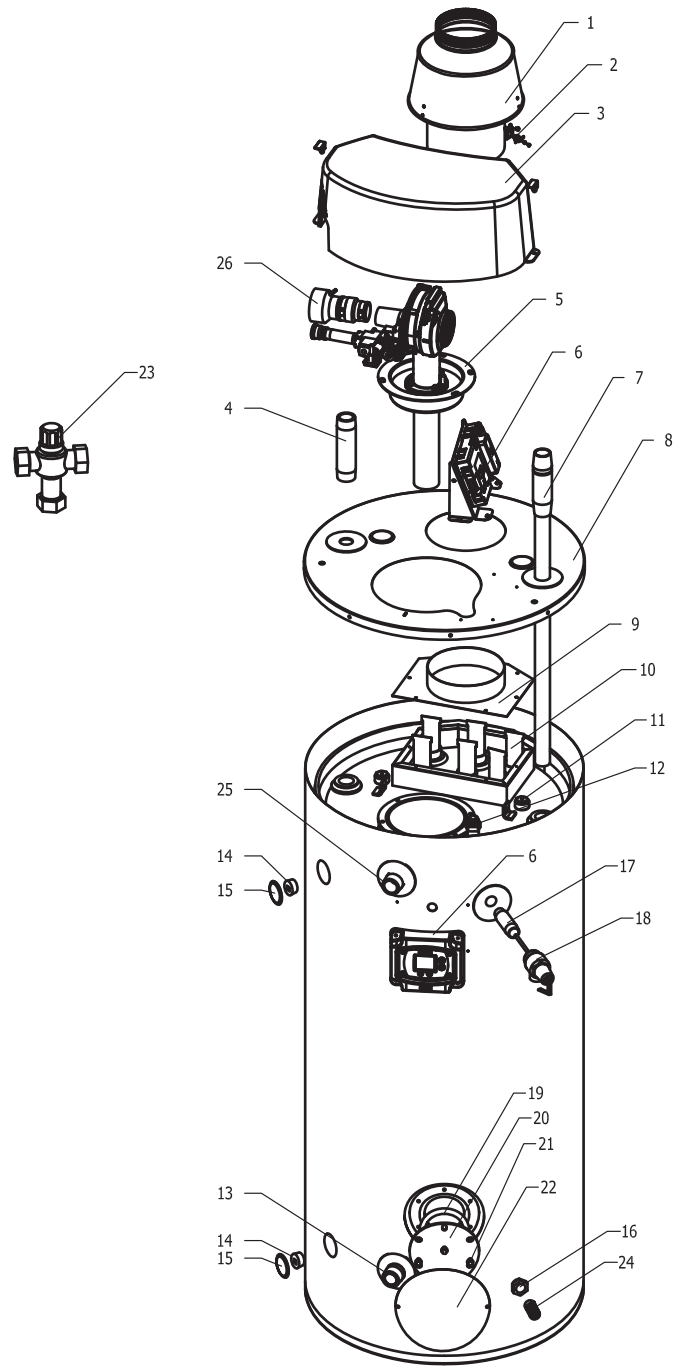

Item	Description	Model	Model	Model	Model
		UCG100H3993N	UCG100H3993X	UCG80H3993N	UCG80H3993X
1	Draft Diverter	239-49610-03	239-49610-03	239-49610-03	239-49610-03
2	Assembly Blocked Vent Switch	239-49622-00	239-49622-00	239-49622-00	239-49622-00
3	Surround with Latches	239-50510-00	239-50510-00	239-50510-00	239-50510-00
4	Nipple Hot Water Outlet Plastisert (Top Connection)	229-40913-01	229-40913-01	229-40913-01	229-40913-01
5	Combustion System Assembly	243-51210-01	243-51210-02	243-51210-03	243-51210-04
6	Control Panel Assembly	(see page 18)	(see page 18)	(see page 18)	(see page 18)
7	Inlet Tube Hydrojet (Top Connection)	229-46709-02	229-46709-02	229-46709-01	229-46709-01
8	Jacket Head	239-51297-01	239-51297-01	239-51297-01	239-51297-01
9	Exhaust Collector Cover	239-50530-03	239-50530-03	239-50530-03	239-50530-03
10	Baffle 2" Flue (6 Req'd)	239-50512-05	239-50512-05	239-50949-03	239-50949-03
11	Anode (Magnesium) (up to 3 req'd)	224-47782-07	224-47782-07	224-47782-05	224-47782-05
	Anode (Aluminum) (up to 3 req'd)	224-38508-10	224-38508-10	224-38508-04	224-38508-04
	Anode (Aluminum A420) (up to 3 req'd)#	224-49559-04	224-49559-04	224-49559-04	224-49559-04
12	Well Sensor	233-46558-03	233-46558-03	233-46558-03	233-46558-03
13	Inlet Tube Hydrojet (Front Connection)	229-44375-00	229-44375-00	229-44375-00	229-44375-00
14	Plug (2 Req'd)	239-02048-00	239-02048-00	239-02048-00	239-02048-00
15	Hole Closure (4 Req'd)	239-31547-02	239-31547-02	239-31547-02	239-31547-02
16	1" to 3/4" Bushing	239-02052-00	239-02052-00	239-02052-00	239-02052-00
17	T&P Nipple	229-50053-02	229-50053-02	229-50053-02	229-50053-02
18	T&P Valve	230-33630-04	230-33630-04	230-33630-04	230-33630-04
19	Cleanout Gasket	205-18427-00	205-18427-00	205-18427-00	205-18427-00
20	Cleanout Cover	205-18428-00	205-18428-00	205-18428-00	205-18428-00
21	Screw 5/16 - 18 x 1/2 (6 req'd)	239-82166-00	239-82166-00	239-82166-00	239-82166-00
22	Clean Out Cover Access	243-20299-00	243-20299-00	243-20299-00	243-20299-00
23	Mixing Device (Optional)	239-51778-00	239-51778-00	239-51778-00	239-51778-00
24	Drain Valve Brass (No Handle)	265-42351-02	265-42351-02	265-42351-02	265-42351-02
25	Nipple Hot Water Outlet Plastisert (Front Connection)	229-40913-07	229-40913-07	229-40913-07	229-40913-07
26	Vent Terminal	239-51226-00	239-51226-00	239-51226-00	239-51226-00

A420 anode may need to be cut to length.

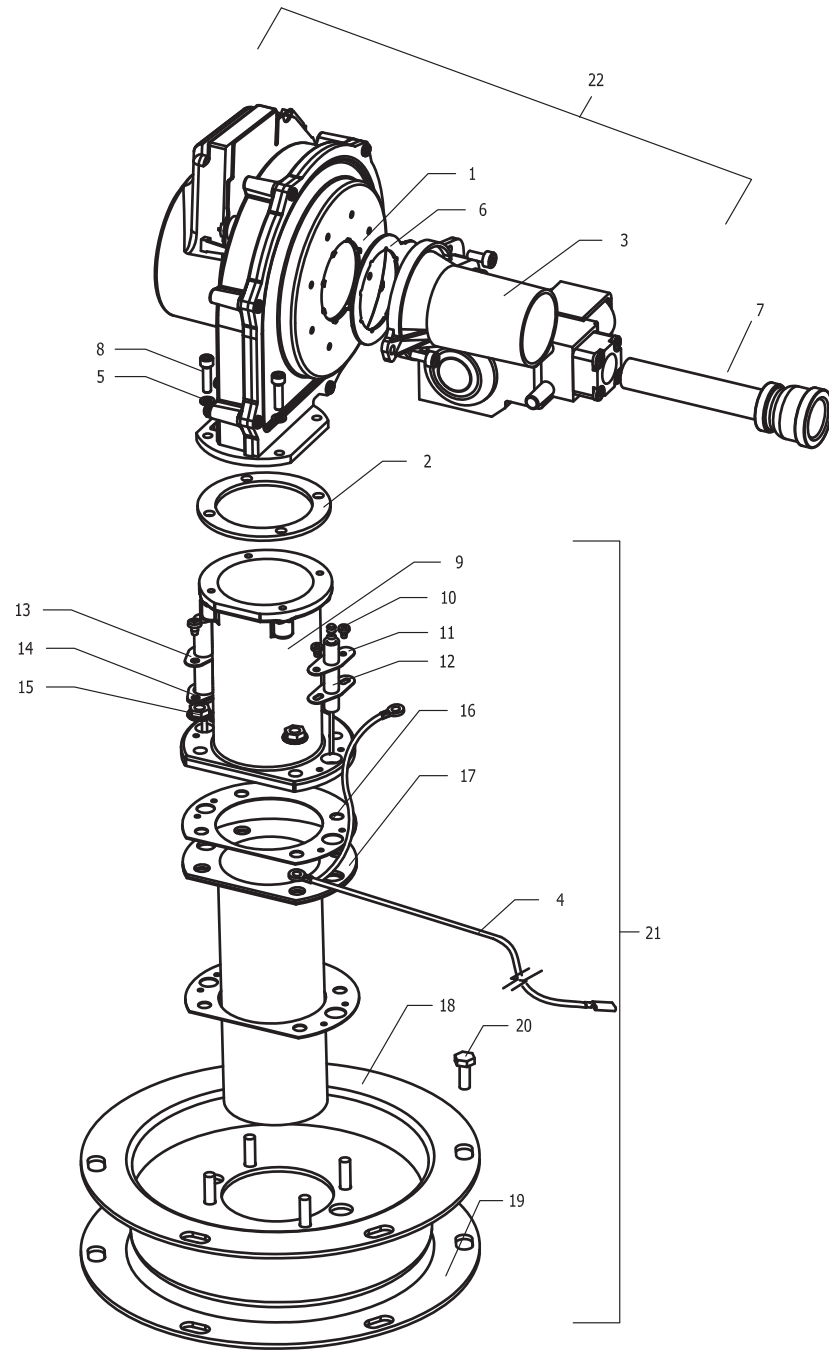

Item	Description	Model	Model	Model	Model
		UCG100H1993N	UCG100H1993X	UCG100H2703N	UCG100H2703X
1	Blower w/Gasket	415-51225-00	415-51225-00	415-48922-00	415-48922-00
2	Blower Transition Gasket	239-43241-00	239-43241-00	239-43241-00	239-43241-00
3	Venturi & Gas Valve Assembly	243-51208-02	243-51726-02	243-51208-03	243-51726-03
4	Ground Wire	239-51994-00	239-51994-00	239-51994-00	239-51994-00
5	Washer - #10 Lockwasher (Req'd)	239-18461-00	239-18461-00	239-18461-00	239-18461-00
6	Venturi Gasket ◊	239-44654-00	239-44654-00	239-44654-00	239-44654-00
7	Gas Piping assembly	243-50524-00	243-50524-00	243-50524-00	243-50524-00
8	Screw 10-32 x .75 Skt Head Cap (4 Req'd)	239-43273-00	239-43273-00	239-43273-00	239-43273-00
9	Transition Tube Blower to Burner	239-43201-00	239-43201-00	239-43201-00	239-43201-00
10	Screw - #8-32 x 1/4 (4 Req'd)	239-43272-00	239-43272-00	239-43272-00	239-43272-00
11	Flame Sensor	415-43232-00	415-43232-00	415-43232-00	415-43232-00
12	Gasket Flame Sensor	239-43371-00	239-43371-00	239-43371-00	239-43371-00
13	Igniter	415-49655-00	415-49655-00	415-49655-00	415-49655-00
14	Gasket Igniter	239-43370-00	239-43370-00	239-43370-00	239-43370-00
15	Nut Hex Washer (4 req'd for Trans Tube)	239-43297-00	239-43297-00	239-43297-00	239-43297-00
16	Gasket Burner (2 Req'd)●	239-43246-00	239-43246-00	239-43246-00	239-43246-00
17	Burner	265-53033-00	265-53033-00	265-53033-00	265-53033-00
18	Burner Mounting Assembly	239-43167-00	239-43167-00	239-43167-00	239-43167-00
19	Combustion Assembly Gasket	239-43197-00	239-43197-00	239-43197-00	239-43197-00
20	Screw 5/16-18 x 3/4 (5 Req'd)	239-32970-00	239-32970-00	239-32970-00	239-32970-00
21	Burner Assembly *	243-50527-00	243-50527-00	243-50527-00	243-50527-00
22	Blower and Gas Valve Assembly *	243-50525-01	243-50525-02	243-50525-03	243-50525-04

* Ordering a complete assembly may increase delivery time. Please order the specific component required for the quickest delivery.

◊ Included with Item 1 & 3

● Included with Items 17 & 21

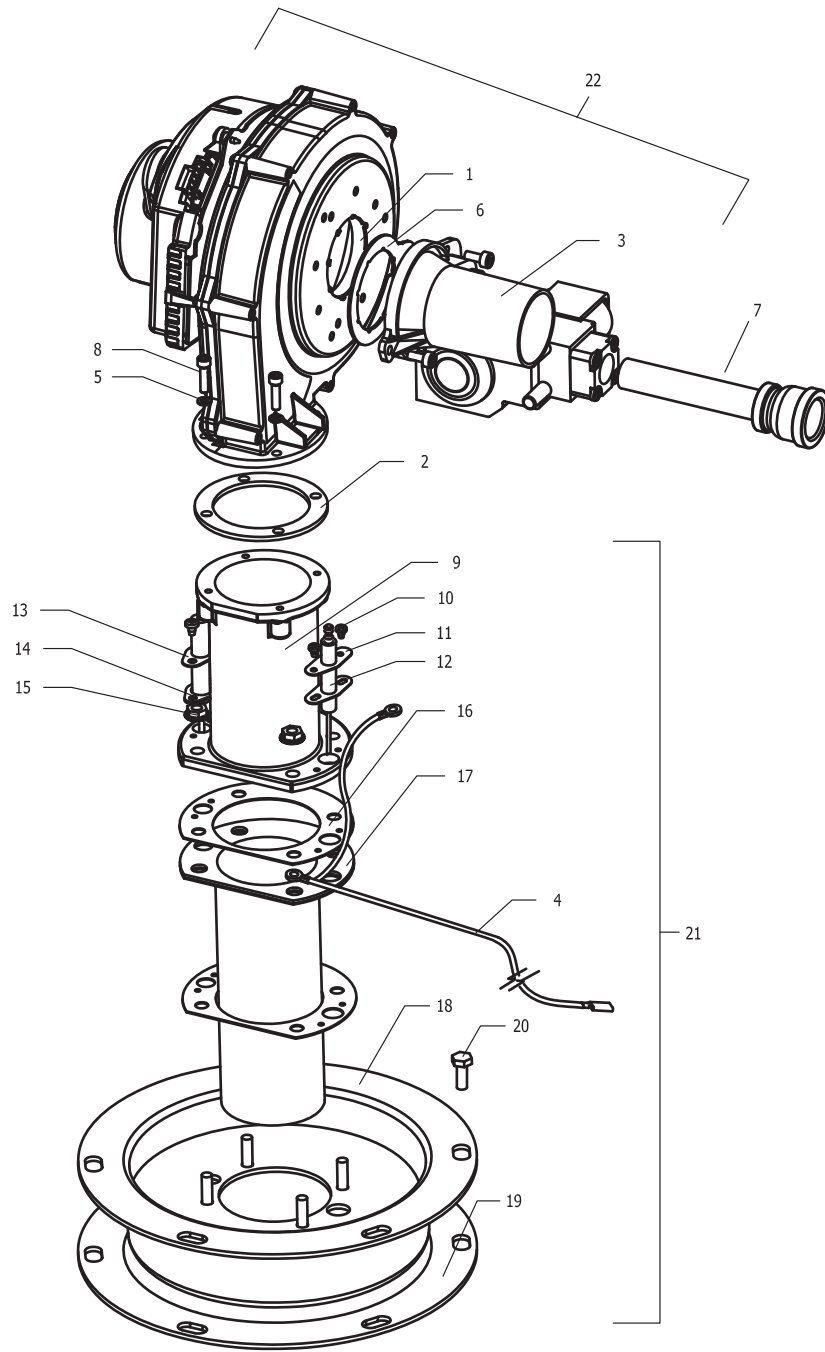

Item	Description	Model	Model	Model	Model	Model	Model
		UCG80H1253N	UCG80H1253X	UCG80H1993N	UCG80H1993X	UCG80H2703N	UCG80H2703X
1	Blower w/Gasket	415-51225-00	415-48922-00	415-51225-00	415-51225-00	415-48922-00	415-48922-00
2	Blower Transition Gasket	239-43241-00	239-43241-00	239-43241-00	239-43241-00	239-43241-00	239-43241-00
3	Venturi & Gas Valve Assembly	243-51208-04	243-51726-04	243-51208-05	243-51726-05	243-51208-06	243-51726-06
4	Ground Wire	239-51994-00	239-51994-00	239-51994-00	239-51994-00	239-51994-00	239-51994-00
5	Washer - #10 Lockwasher (Req'd)	239-18461-00	239-18461-00	239-18461-00	239-18461-00	239-18461-00	239-18461-00
6	Venturi Gasket ◊	239-44654-00	239-44654-00	239-44654-00	239-44654-00	239-44654-00	239-44654-00
7	Gas Piping assembly	243-50524-00	243-50524-00	243-50524-00	243-50524-00	243-50524-00	243-50524-00
8	Screw 10-32 x .75 Skt Head Cap (4 Req'd)	239-43273-00	239-43273-00	239-43273-00	239-43273-00	239-43273-00	239-43273-00
9	Transition Tube Blower to Burner	239-43201-00	239-43201-00	239-43201-00	239-43201-00	239-43201-00	239-43201-00
10	Screw - #8-32 x 1/4 (4 Req'd)	239-43272-00	239-43272-00	239-43272-00	239-43272-00	239-43272-00	239-43272-00
11	Igniter	415-49655-00	415-49655-00	415-49655-00	415-49655-00	415-49655-00	415-49655-00
12	Gasket Igniter	239-43371-00	239-43371-00	239-43371-00	239-43371-00	239-43371-00	239-43371-00
13	Flame Sensor	415-43232-00	415-43232-00	415-43232-00	415-43232-00	415-43232-00	415-43232-00
14	Gasket Flame Sensor	239-43370-00	239-43370-00	239-43370-00	239-43370-00	239-43370-00	239-43370-00
15	Nut Hex Washer (4 req'd for Trans Tube)	239-43297-00	239-43297-00	239-43297-00	239-43297-00	239-43297-00	239-43297-00
16	Gasket Burner (2 Req'd)●	239-43246-00	239-43246-00	239-43246-00	239-43246-00	239-43246-00	239-43246-00
17	Burner	265-53033-00	265-53033-00	265-53033-00	265-53033-00	265-53033-00	265-53033-00
18	Burner Mounting Assembly	239-43167-00	239-43167-00	239-43167-00	239-43167-00	239-43167-00	239-43167-00
19	Combustion Assembly Gasket	239-43197-00	239-43197-00	239-43197-00	239-43197-00	239-43197-00	239-43197-00
20	Screw 5/16-18 x 3/4 (5 Req'd)	239-32970-00	239-32970-00	239-32970-00	239-32970-00	239-32970-00	239-32970-00
21	Burner Assembly *	243-50527-00	243-50527-00	243-50527-00	243-50527-00	243-50527-00	243-50527-00
22	Blower and Gas Valve Assembly *	243-50525-07	243-50525-08	243-50525-09	243-50525-10	243-50525-11	243-50525-12

* Ordering a complete assembly may increase delivery time. Please order the specific component required for the quickest delivery.

◊ Included with Item 1 & 3

● Included with Items 17 & 21

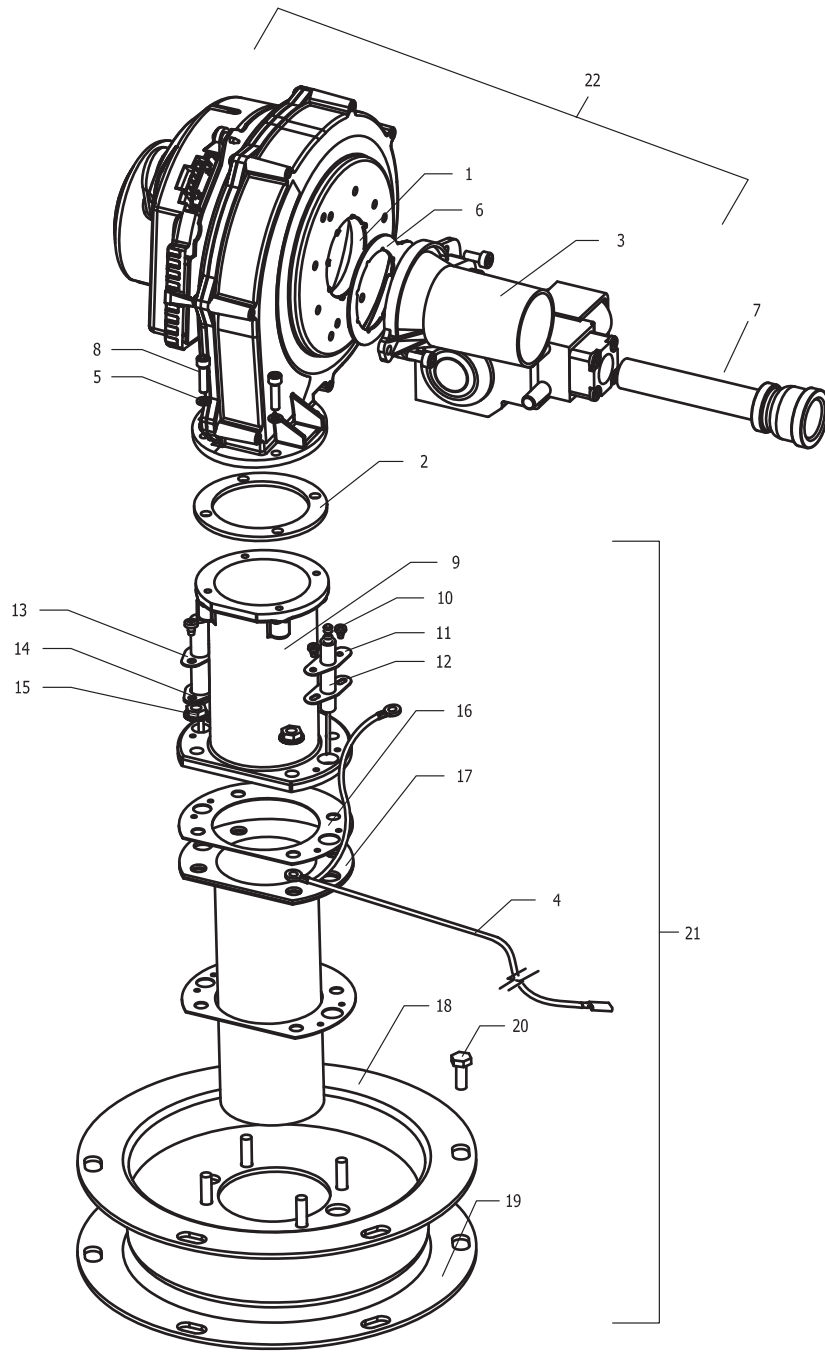

Item	Description	Model	Model	Model	Model
		UCG100H3993N	UCG100H3993X	UCG80H3993N	UCG80H3993X
1	Blower w/Gasket	415-51428-00	415-51428-00	415-51428-00	415-51428-00
2	Blower Transition Gasket	239-43241-00	239-43241-00	239-43241-00	239-43241-00
3	Venturi & Gas Valve Assembly	243-51208-01	243-51726-01	243-51208-07	243-51726-07
4	Ground Wire	239-51994-00	239-51994-00	239-51994-00	239-51994-00
5	Washer - #10 Lockwasher (Req'd)	239-18461-00	239-18461-00	239-18461-00	239-18461-00
6	Venturi Gasket ◊	239-44654-00	239-44654-00	239-44654-00	239-44654-00
7	Gas Piping assembly	243-50524-00	243-50524-00	243-50524-00	243-50524-00
8	Screw 10-32 x .75 Skt Head Cap (4 Req'd)	239-43273-00	239-43273-00	239-43273-00	239-43273-00
9	Transition Tube Blower to Burner	239-43201-00	239-43201-00	239-43201-00	239-43201-00
10	Screw - #8-32 x 1/4 (4 Req'd)	239-43272-00	239-43272-00	239-43272-00	239-43272-00
11	Igniter	233-43232-00	233-43232-00	233-43232-00	233-43232-00
12	Gasket Flame Sensor	239-43371-00	239-43371-00	239-43371-00	239-43371-00
13	Flame Sensor	415-46481-00	415-46481-00	415-46481-00	415-46481-00
14	Gasket Igniter	239-43370-00	239-43370-00	239-43370-00	239-43370-00
15	Nut Hex Washer (4 req'd for Trans Tube)	239-43297-00	239-43297-00	239-43297-00	239-43297-00
16	Gasket Burner (2 Req'd)●	239-43246-00	239-43246-00	239-43246-00	239-43246-00
17	Burner	265-53033-00	265-53033-00	265-53033-00	265-53033-00
18	Burner Mounting Assembly	239-43167-00	239-43167-00	239-43167-00	239-43167-00
19	Combustion Assembly Gasket	239-43197-00	239-43197-00	239-43197-00	239-43197-00
20	Screw 5/16-18 x 3/4 (5 Req'd)	239-32970-00	239-32970-00	239-32970-00	239-32970-00
21	Burner Assembly *	243-51232-00	243-51232-00	243-51232-00	243-51232-00
22	Blower and Gas Valve Assembly *	243-50525-05	243-50525-06	243-50525-13	243-50525-14

* Ordering a complete assembly may increase delivery time. Please order the specific component required for the quickest delivery.

◊ Included with Item 1 & 3

● Included with Items 17 & 21

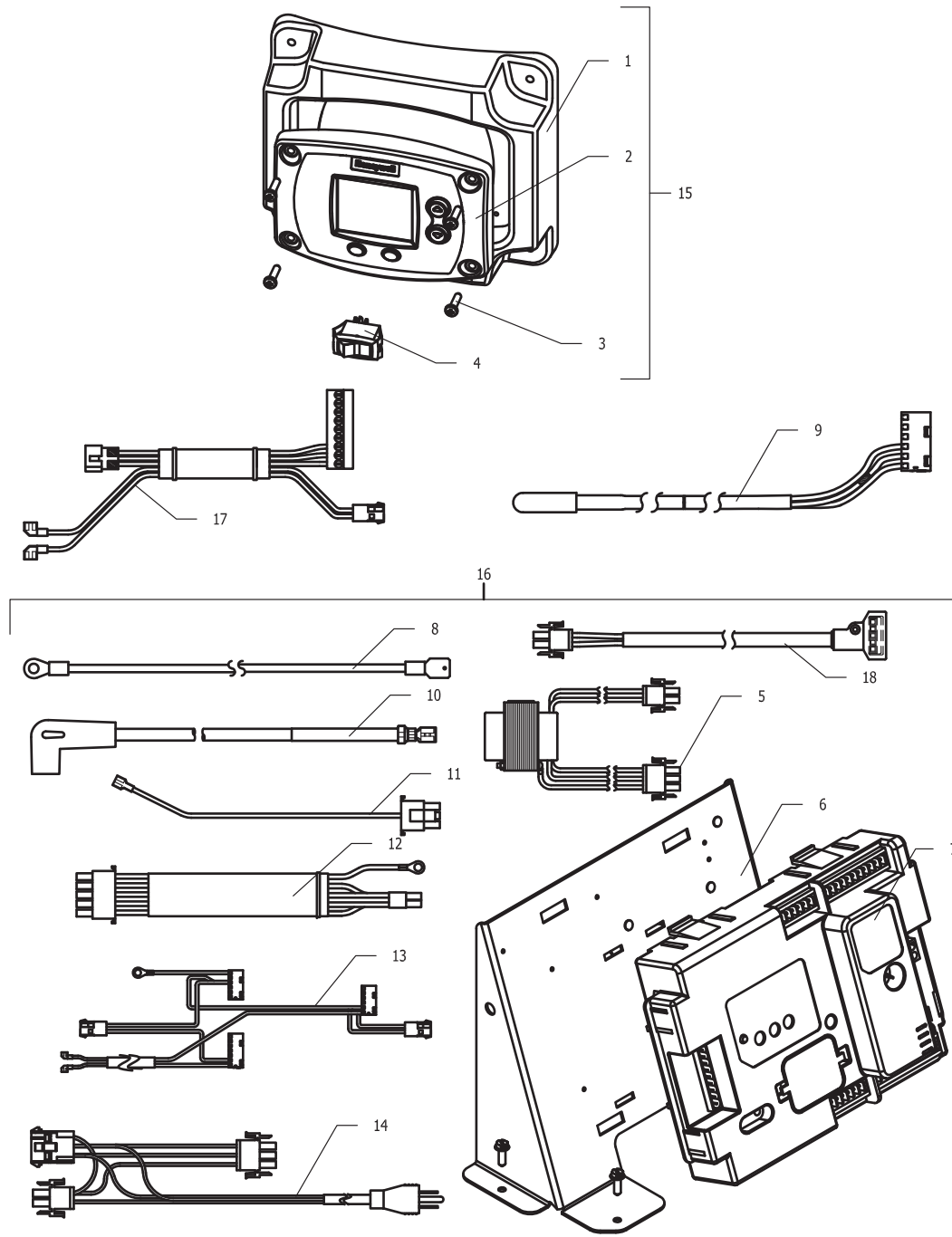

Item	Description	Model	Model	Model	Model
		***UCG100H1993N	***UCG100H1993X	***UCG100H2703N	***UCG100H2703X
1	Display Mount	239-50508-00	239-50508-00	239-50508-00	239-50508-00
2	Control Display-Honeywell Integrated Control	415-46557-00	415-46557-00	415-46557-00	415-46557-00
3	Screw-#8-18 X .75 for Control Display (4 req'd)	239-41104-00	239-41104-00	239-41104-00	239-41104-00
4	Main Power Switch	239-50586-00	239-50586-00	239-50586-00	239-50586-00
5	Transformer 120V to 24V	233-50559-00	233-50559-00	233-50559-00	233-50559-00
6	Control Panel	239-50514-00	239-50514-00	239-50514-00	239-50514-00
7	Integrated Control Board	415-46954-00	415-46954-00	415-46954-00	415-46954-00
8	Ground Wire	239-38951-88	239-38951-88	239-38951-88	239-38951-88
9	T-Stat Sensor Harness	239-46553-02	239-46553-02	239-46553-02	239-46553-02
10	High Voltage Spark Cable	239-50593-00	239-50593-00	239-50593-00	239-50593-00
11	Flame Sensor Wire	239-38951-84	239-38951-84	239-38951-84	239-38951-84
12	Blower Harness	239-46865-00	239-46865-00	239-46865-00	239-46865-00
13	Ignition Control Harness	239-50595-00	239-50595-00	239-50595-00	239-50595-00
14	Power Cord Harness	239-50596-00	239-50596-00	239-50596-00	239-50596-00
15	Display Assembly*	243-50561-00	243-50561-00	243-50561-00	243-50561-00
16	Control Assembly*	243-50560-00	243-50560-00	243-50560-00	243-50560-00
17	Control to Display Harness	239-50594-00	239-50594-00	239-50594-00	239-50594-00

* Ordering a complete assembly may increase delivery time. Please order the specific component required for the quickest delivery.

*** Prior to Serial # PL40538368

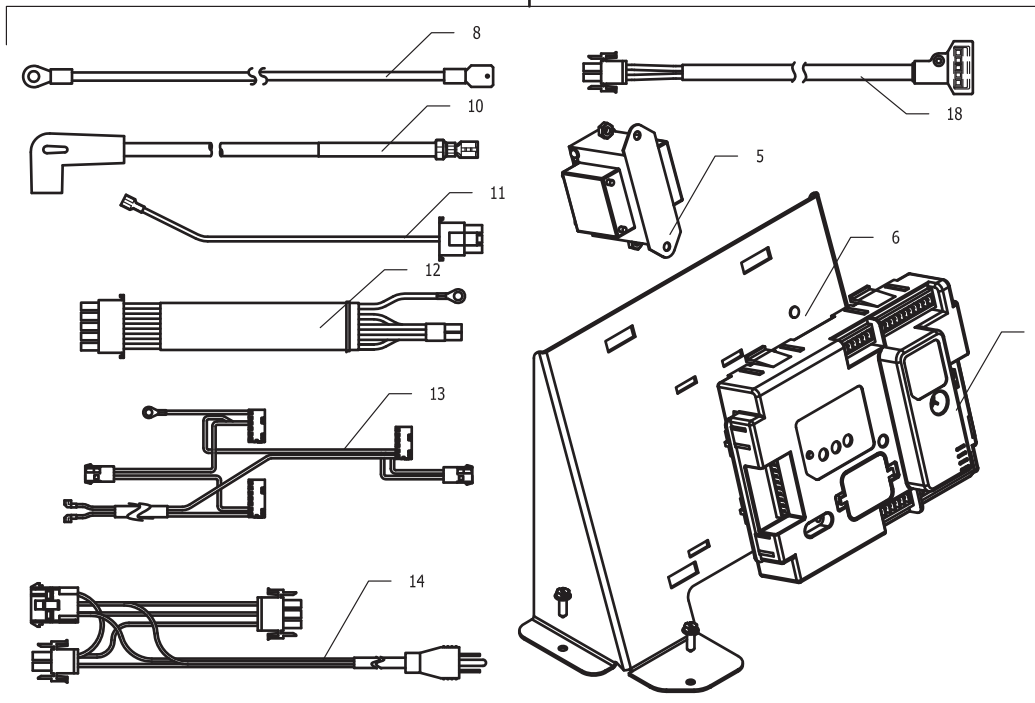
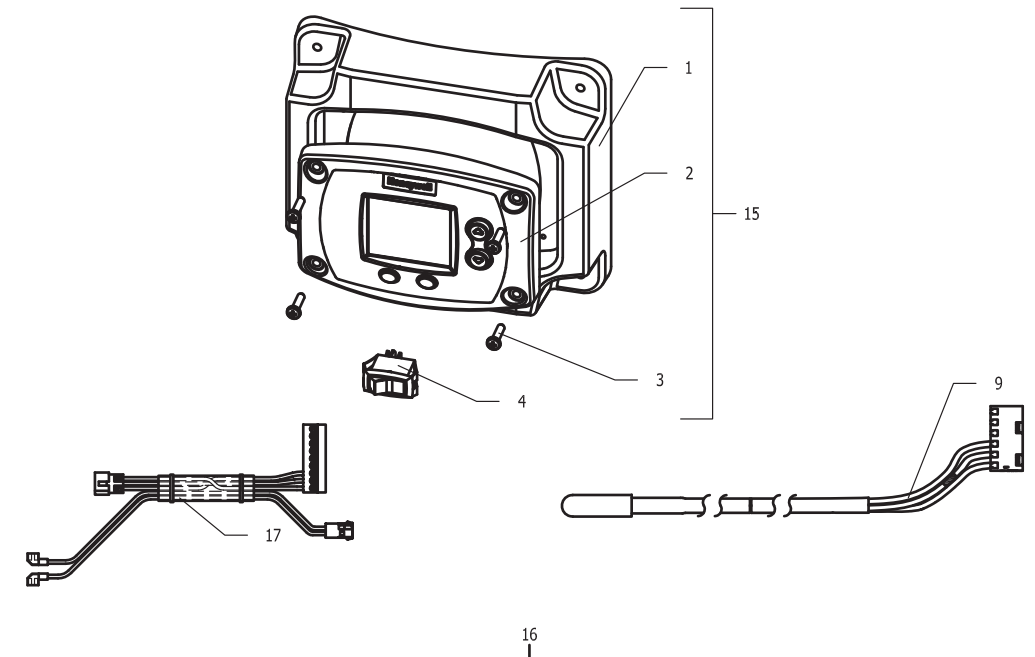

16

Item	Description	Model UCG80H1253N	Model UCG80H1253X	Model **UCG80H1993N	Model **UCG80H1993X	Model **UCG80H2703N	Model **UCG80H2703X
1	Display Mount	239-50508-00	239-50508-00	239-50508-00	239-50508-00	239-50508-00	239-50508-00
2	Control Display-Honeywell Integrated Control	415-46557-00	415-46557-00	415-46557-00	415-46557-00	415-46557-00	415-46557-00
3	Screw-#8-18 X .75 for Control Display (4 req'd)	239-41104-00	239-41104-00	239-41104-00	239-41104-00	239-41104-00	239-41104-00
4	Main Power Switch	239-50586-00	239-50586-00	239-50586-00	239-50586-00	239-50586-00	239-50586-00
5	Transformer 120V to 24V	233-50559-00	233-50559-00	233-50559-00	233-50559-00	233-50559-00	233-50559-00
6	Control Panel	239-50514-00	239-50514-00	239-50514-00	239-50514-00	239-50514-00	239-50514-00
7	Integrated Control Board	415-46954-00	415-46954-00	415-46954-00	415-46954-00	415-46954-00	415-46954-00
8	Ground Wire	239-38951-88	239-38951-88	239-38951-88	239-38951-88	239-38951-88	239-38951-88
9	T-Stat Sensor Harness	239-46553-02	239-46553-02	239-46553-02	239-46553-02	239-46553-02	239-46553-02
10	High Voltage Spark Cable	239-50593-00	239-50593-00	239-50593-00	239-50593-00	239-50593-00	239-50593-00
11	Flame Sensor Wire	239-38951-84	239-38951-84	239-38951-84	239-38951-84	239-38951-84	239-38951-84
12	Blower Harness	239-46865-00	239-46865-00	239-46865-00	239-46865-00	239-46865-00	239-46865-00
13	Ignition Control Harness	239-50595-00	239-50595-00	239-50595-00	239-50595-00	239-50595-00	239-50595-00
14	Power Cord Harness	239-50596-00	239-50596-00	239-50596-00	239-50596-00	239-50596-00	239-50596-00
15	Display Assembly*	243-50561-00	243-50561-00	243-50561-00	243-50561-00	243-50561-00	243-50561-00
16	Control Assembly*	243-50560-00	243-50560-00	243-50560-00	243-50560-00	243-50560-00	243-50560-00
17	Control to Display Harness	239-50594-00	239-50594-00	239-50594-00	239-50594-00	239-50594-00	239-50594-00

* Ordering a complete assembly may increase delivery time. Please order the specific component required for the quickest delivery.

** Prior to Serial # PL40538368 Except UCG80H1253N(X)

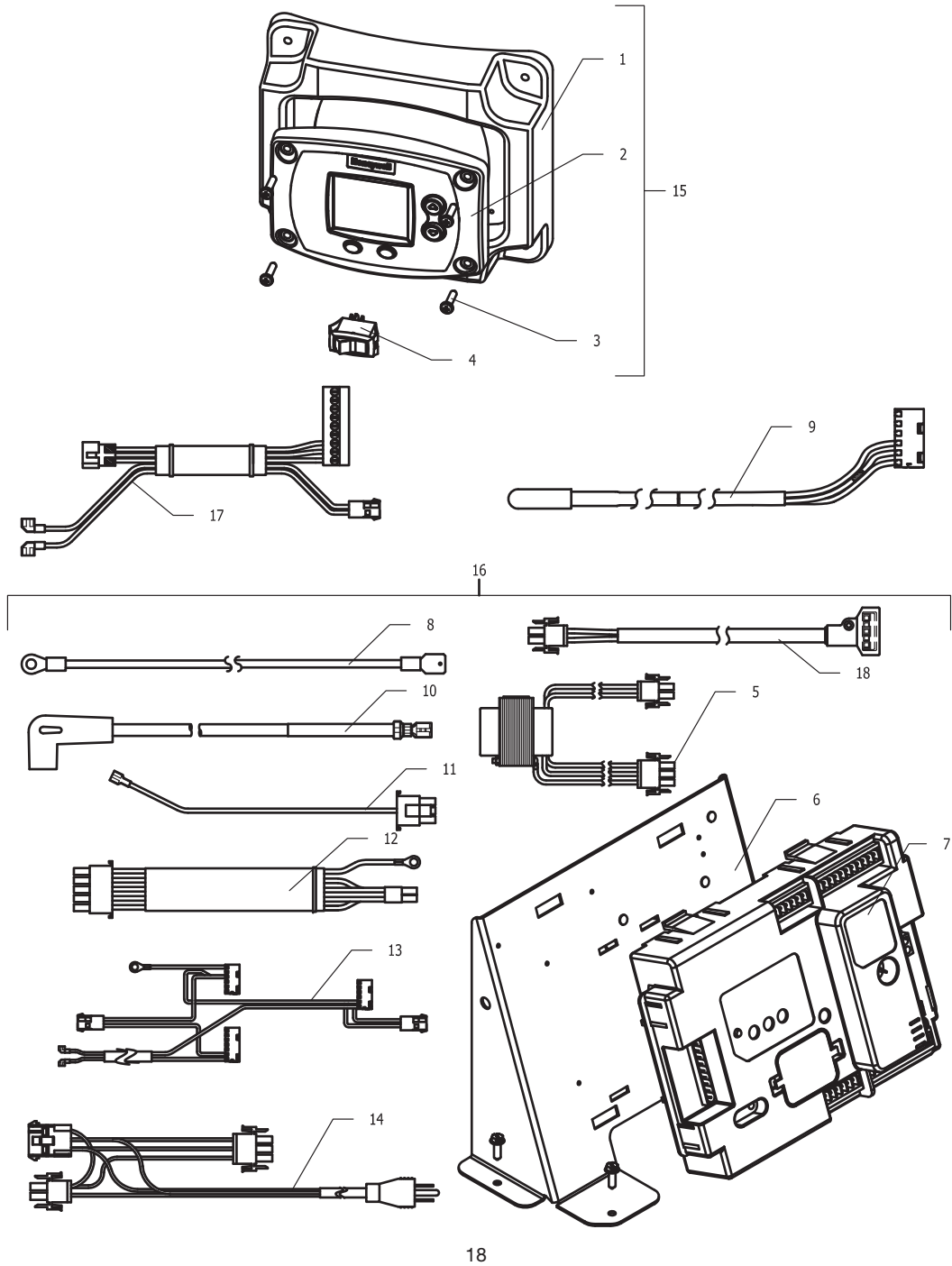

Item	Description	Model ***UCG100H199/270(N/X)	Model ***UCG80H199/2703(N/X)	Model UCG100H3993(N/X)	Model UCG80H3993(N/X)
1	Display Mount	239-50508-00	239-50508-00	239-50508-00	239-50508-00
2	Control Display-Honeywell Integrated Control	415-48231-00	415-48231-00	415-48231-00	415-48231-00
3	Screw-#8-18 X .75 for Control Display (4 req'd)	239-41104-00	239-41104-00	239-41104-00	239-41104-00
4	Main Power Switch	239-50586-00	239-50586-00	239-50586-00	239-50586-00
5	Transformer 120V to 24V	233-50559-00	233-50559-00	233-50559-00	233-50559-00
6	Control Panel	239-50514-00	239-50514-00	239-50514-00	239-50514-00
7	Honeywell Module	415-51229-00	415-51229-00	415-51229-00	415-51229-00
8	Ground Wire	239-38951-88	239-38951-88	239-38951-88	239-38951-88
9	T-Stat Sensor Harness	239-48587-00	239-48587-00	239-48587-00	239-48587-00
10	High Voltage Spark Cable	239-46861-00	239-46861-00	239-46861-00	239-46861-00
11	Flame Sensor Wire	239-48237-00	239-48237-00	239-48237-00	239-48237-00
12	Blower Harness	239-48170-00	239-48170-00	239-48170-00	239-48170-00
13	Ignition Control Harness	239-51211-00	239-51211-00	239-51211-00	239-51211-00
14	Power Cord Harness	239-51212-00	239-51212-00	239-51212-00	239-51212-00
15	Display Assembly*	243-51213-00	243-51213-00	243-51213-00	243-51213-00
16	Control Assembly*	243-51228-00	243-51228-00	243-51228-00	243-51228-00
17	Control to Display Harness	239-51209-00	239-51209-00	239-51209-00	239-51209-00
18	Gas Valve Harness	239-43571-00	239-43571-00	239-43571-00	239-43571-00

* Ordering a complete assembly may increase delivery time. Please order the specific component required for the quickest delivery.

***Serial # PL40538368 And After for UCG80/100H1993N(X) and UCG80/100H2703N(X)

Reference Chart of Anode Length by Model

Model	AOD Anode Cut (End to end)		Hex Head Anode Cut Length (End to end)	
	Inches	Millimeters	Inches	Millimeters
UCG100H	---	---	43.5	1105
UCG80H	---	---	35	889



United States

Sales 800-523-2931

Technical Support 800-334-3393

Email techserv@bradfordwhite.com

Warranty 800-531-2111

Email warranty@bradfordwhite.com

Service Parts 800-538-2020

Email parts@bradfordwhite.com

Canada

Sales & Technical Support 866-690-0961 905-03-0600

Fax 905-636-0666

Warranty bwccwarranty@bradfordwhite.com

Technical Support bwccotech@bradfordwhite.com

Service Parts orders@bradfordwhitecanada.com

Orders ca.orders@bradfordwhite.com

For U.S. and Canada field service,
contact your professional installer or
local Bradford White sales representative.

International

General Contact international@bradfordwhite.com