



LIGHT DUTY COMMERCIAL ELECTRIC REPLACEMENT PARTS LIST

Light Duty Energy Saver Upright Models Light Duty Energy Saver Lowboy Models



*Effective: November, 2018
ECO 8228*

**NOTE: BOTH MODEL AND SERIAL
NUMBERS ARE REQUIRED FOR
ORDERING REPLACEMENT PARTS**

Dimensions and specifications
subject to change without notice.



As required by the state of California Proposition 65.

TOP LOCATION
 ● Double element water heater.

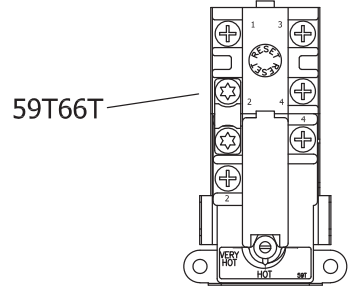

BOTTOM LOCATION
 ● Single element water heater.
 ● Double element water heater.

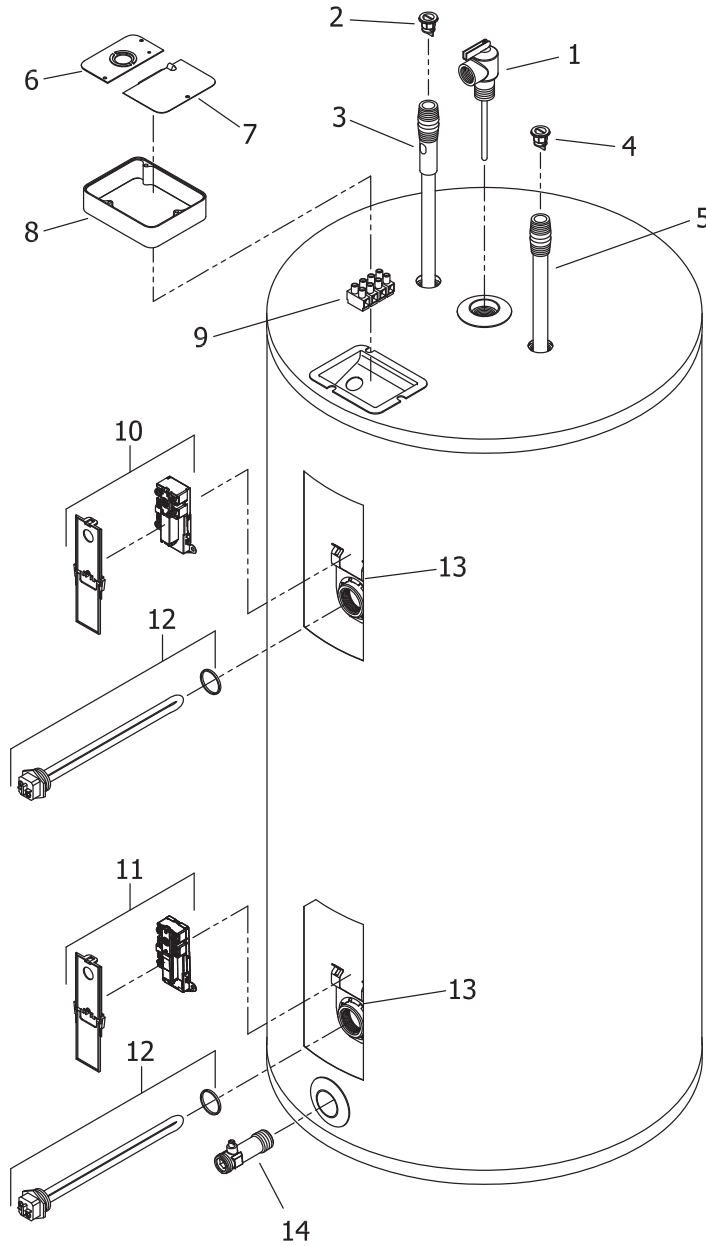
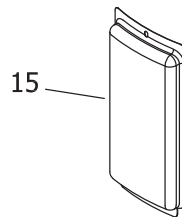
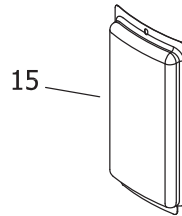
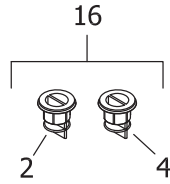
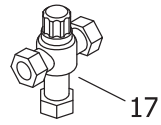
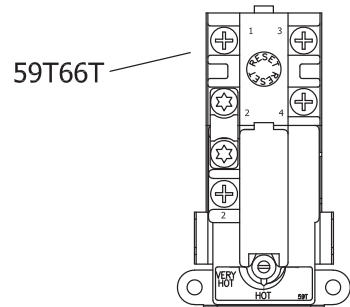

Item	Description	Model	Model	Model
		LE230S	LE240S	LE250S
1	T&P Relief Valve	230-32920-01	230-32920-01	230-32920-01
2	Heat Trap Insert (Outlet)	239-45167-00	239-45167-00	239-45167-00
3	Hot Water Outlet Anode Magnesium ♦#	224-47776-19	224-47776-19	224-47776-19
	Aluminum ♦#	224-32999-28	224-32999-28	224-32999-28
	A420 (Aluminum) ♦#	224-49560-08	224-49560-08	224-49560-08
4	Heat Trap Insert (Inlet)	239-51556-00	239-51556-00	239-51556-00
5	Cold Water Inlet Tube Pex ♦♦	229-51230-21	229-51230-21	229-51230-21
6	Cover Conduit/Ground	243-39451-00	243-39451-00	243-39451-00
7	Cover Junction box	243-39452-00	243-39452-00	243-39452-00
8	Junction Box Extender	239-40587-00	239-40587-00	239-40587-00
9	Terminal Block (4 pole)	239-47294-00	239-47294-00	239-47294-00
10	Upper Thermostat with High Limit (59T66T) & Protector ▲	415-53389-00	415-53389-00	415-53389-00
11	Lower Thermostat with High Limit (59T66T) & Protector ▲	415-53388-00	415-53388-00	415-53388-00
12	Heating Element 240V 4500W with gasket*	265-48642-00	265-48642-00	265-48642-00
13	Thermostat Mounting Bracket	239-50689-00	239-50689-00	239-50689-00
14	Brass Drain Valve	265-42351-02	265-42351-02	265-42351-02
15	Access Cover	243-36618-02	243-36618-02	243-36618-02
16	Kit-Heat Trap Insert	265-51572-00	265-51572-00	265-51572-00
17	ASSE Approved Mixing Valve	239-51778-00	239-51778-00	239-51778-00

♦ Order with item 2.

♦♦ Order with item 4.

▲ Thermostat protector and mounting bracket (Item #13) provided in kit with thermostat.

* For other voltage and wattage combinations, refer to heating element on pages 6 & 7.

Anode may need to be cut to length

TOP LOCATION
 ● Double element water heater.

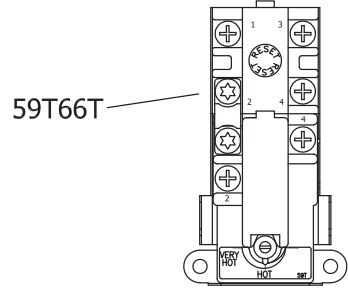

BOTTOM LOCATION
 ● Single element water heater.
 ● Double element water heater.

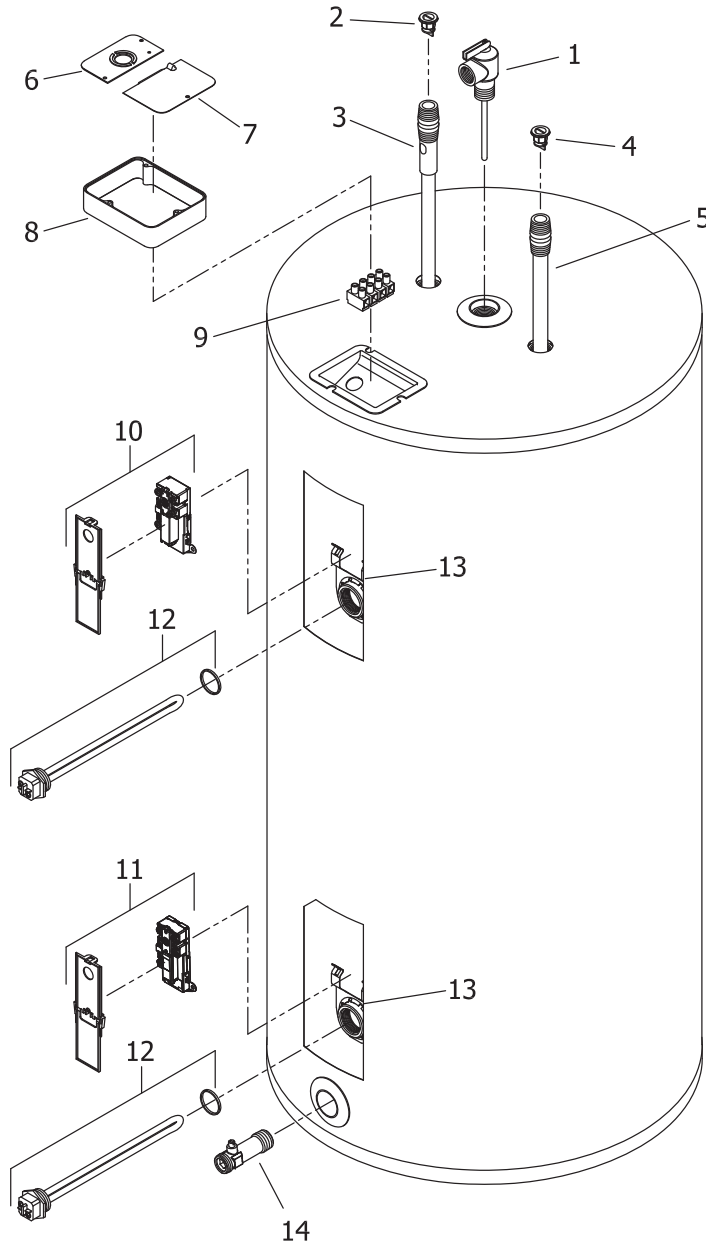
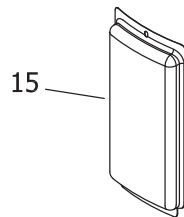
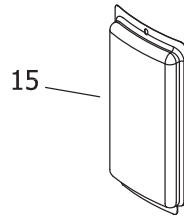
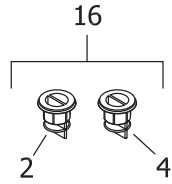
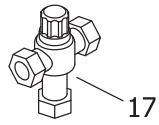
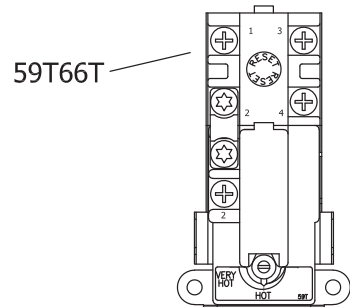

Item	Description	Model LE120L	Model LE130L	Model LE140L	Model LE150L
1	T&P Relief Valve	230-32920-01	230-40594-02	230-40594-02	230-40594-02
2	Heat Trap Insert (Outlet)	239-45167-00	239-45167-00	239-45167-00	239-45167-00
3	Hot Water Outlet Anode Magnesium ♦#	224-47776-19	224-47776-19	224-47776-19	224-47776-19
	Aluminum ♦#	224-32999-28	224-32999-28	224-32999-28	224-32999-28
	A420(Aluminum) ♦#	224-49560-08	224-49560-08	224-49560-08	224-49560-08
4	Heat Trap Insert (Inlet)	239-51556-00	239-51556-00	239-51556-00	239-51556-00
5	Cold Water Inlet Tube PEX ♦♦	229-51230-01	229-51718-04	229-51230-27	229-51230-27
6	Cover Conduit/Ground	243-39451-00	243-39451-00	243-39451-00	243-39451-00
7	Cover Junction box	243-39452-00	243-39452-00	243-39452-00	243-39452-00
8	Junction Box Extender	239-40587-00	239-40587-00	239-40587-00	239-40587-00
9	Terminal Block (4 pole)	239-47294-00	239-47294-00	239-47294-00	239-47294-00
10	Upper Thermostat with High Limit (59T66T) & Protector ▲	415-53389-00	415-53389-00	415-53389-00	415-53389-00
11	Lower Thermostat with High Limit (59T66T) & Protector ▲	415-53388-00	415-53388-00	415-53388-00	415-53388-00
12	Heating Element 240V 4500W with gasket*	265-48642-00	265-48642-00	265-48642-00	265-48642-00
13	Thermostat Mounting Bracket	239-50689-00	239-50689-00	239-50689-00	239-50689-00
14	Brass Drain Valve	265-42351-02	265-42351-02	265-42351-02	265-42351-02
15	Access Cover	243-36618-02	243-36618-02	243-36618-02	243-36618-02
16	Kit-Heat Trap Insert	265-51572-00	265-51572-00	265-51572-00	265-51572-00
17	ASSE Approved Mixing Valve	239-51778-00	239-51778-00	239-51778-00	239-51778-00

♦ Order with item 2.

♦♦ Order with item 4.

▲ Thermostat protector and mounting bracket (Item #13) provided in kit with thermostat.

* For other voltage and wattage combinations, refer to heating elements on page 6 & 7.

Anode may need to be cut to length

TOP LOCATION
 ● Double element water heater.

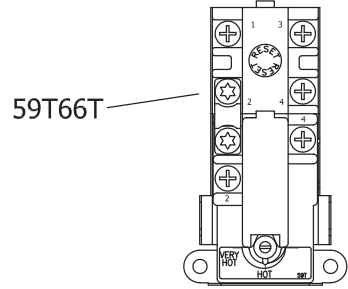

BOTTOM LOCATION
 ● Single element water heater.
 ● Double element water heater.

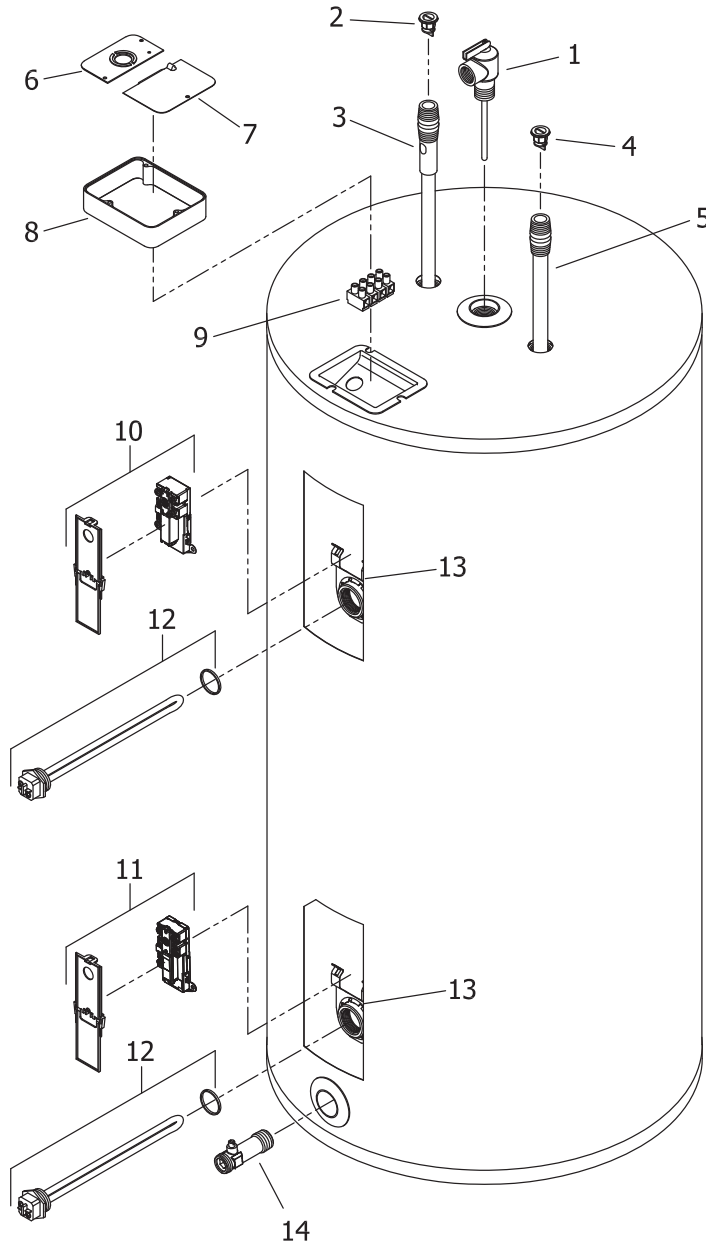
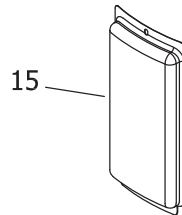
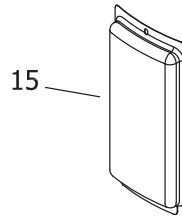
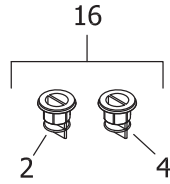
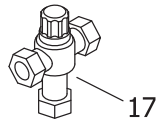
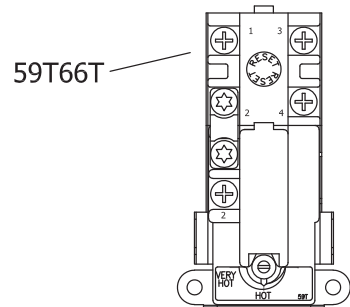

Item	Description	Model LE265T	Model LE280T	Model LE2120T
1	T&P Relief Valve	230-40594-02	230-40594-02	230-40594-02
2	Heat Trap Insert (Outlet)	239-45167-00	239-45167-00	239-45167-00
3	Hot Water Outlet Anode Magnesium ♦ #	224-47776-19	224-47776-19	224-47780-01
	Aluminum ♦ #	224-32999-28	224-32999-28	224-45036-01
	A420 (Aluminum)#	224-49560-08	224-49560-08	224-49561-01
4	Heat Trap Insert (Inlet)	239-51556-00	239-51556-00	239-51556-00
5	Cold Water Inlet Tube PEX ♦♦	229-51230-22	229-51230-22	---
	Cold Water Inlet Tube Polysulfone ♦♦	---	---	229-45032-01
6	Cover Conduit/Ground	243-39451-00	243-39451-00	243-39451-00
7	Cover Junction box	243-39452-00	243-39452-00	243-39452-00
8	Junction Box Extender	239-40587-00	239-40587-00	239-40587-00
9	Terminal Block (4 pole)	239-47294-00	239-47294-00	239-47294-00
10	Upper Thermostat with High Limit (59T66T) & Protector ▲	415-53389-00	415-53389-00	415-53389-00
11	Lower Thermostat with High Limit (59T66T) & Protector ▲	415-53388-00	415-53388-00	415-53388-00
12	Heating Element 240V 4500W with gasket*	265-48642-00	265-48642-00	265-48642-00
13	Thermostat Mounting Bracket	239-50689-00	239-50689-00	239-50689-00
14	Brass Drain Valve	265-42351-02	265-42351-02	265-42351-02
15	Access Cover	243-36618-02	243-36618-02	243-36618-02
16	Kit-Heat Trap Insert	265-51572-00	265-51572-00	265-51572-00
17	ASSE Approved Mixing Valve	239-51778-00	239-51778-00	239-51778-00

♦ Order with item 2.

♦♦ Order with item 4.

▲ Thermostat protector and mounting bracket (Item #13) provided in kit with thermostat.

* For other voltage and wattage combinations, refer to heating element on pages 6 & 7.

Anode may need to be cut to length

Voltage & Wattage Conversion Kits

Element Wattage	Non-Simultaneous Max Wattage	Simultaneous Max Wattage	Voltage			
			120	208	240	277
1500	1500	3000	265-46409-01	265-46409-05	265-46409-13	265-45409-16
2000	2000	4000	265-46409-02 *	265-46409-06	265-46409-05	265-45409-17
2500	2500	5000	265-46409-03 *	265-46409-07	265-46409-06	265-45409-18
3000	3000	6000	265-46409-04 *	265-46409-08	265-46409-14	265-45409-19
3500	3500	7000	N/A	265-46409-09	265-46409-07	N/A
4000	4000	8000	N/A	265-46409-10	265-46409-08	265-45409-20
4500	4500	9000	N/A	265-46409-11	265-46409-09	265-45409-21
5000	5000	10000	N/A	265-46409-12	265-46409-15	265-45409-22
5500	5500	11000	N/A	265-46409-46 *	265-46409-10	265-46409-40
6000	6000	12000	N/A	265-46409-47 *	265-46409-48 *	265-45409-23

			380	415	480
1500	1500	3000	265-46409-24	265-46409-41	265-46409-32
2000	2000	4000	265-46409-43	265-46409-24	265-46409-33
2500	2500	5000	265-46409-25	265-46409-43	265-46409-34
3000	3000	6000	265-46409-26	265-46409-25	265-46409-35
3500	3500	7000	265-46409-27	265-46409-26	N/A
4000	4000	8000	265-46409-29	265-46409-27	265-46409-36
4500	4500	9000	265-46409-30	265-46409-28	265-46409-37
5000	5000	10000	265-46409-31	265-46409-29	265-46409-38
5500	5500	11000	265-46409-44	265-46409-30	265-46409-42
6000	6000	12000	265-46409-45	265-46409-31	265-46409-39

* These kits contain only one element for single element water heaters only.

**Heating Elements (Copper) for:
Residential Series (RE)
Light Duty (LE) Commercial Series
Medium Duty (E32) Commercial Series
Commercial (MII) Series**

Wattage	120 Volt	208 Volt	240 Volt	277 Volt	380 Volt
1000W ▲	220-42540-01	220-42544-01	220-42546-01	N/A	N/A
1250W ▲	N/A	N/A	220-42544-13	N/A	N/A
1500W ▲	220-42540-02	220-42544-03	220-42544-01	N/A	N/A
1500W (LWD)▲	220-42540-03	N/A	220-42544-02	N/A	N/A
2000W ▲	220-42540-04	220-42544-04	220-42544-03	N/A	N/A
2500W ▲	220-42540-05	220-42544-06	220-42544-04	N/A	N/A
3000W ▲	220-42540-07	220-42544-14	220-42544-05	N/A	N/A
3500W ▲▲	N/A	220-51333-08	220-42544-06	N/A	N/A
3800W ▲▲	N/A	N/A	220-42546-10	N/A	N/A
4000W ▲▲	N/A	220-42544-16	220-42544-14	N/A	N/A
4500W ▲▲	N/A	220-42544-12	220-51333-08	N/A	N/A
4500W (LWD) ▲▲	N/A	N/A	220-51333-09	N/A	N/A
5000W ▲▲	N/A	N/A	220-42544-10	N/A	N/A
5500W ▲▲	N/A	N/A	220-42544-16	N/A	N/A
6000W ▲▲	N/A	N/A	220-42544-12	N/A	N/A
Element gasket ^	223-34019-00	223-34019-00	223-34019-00	223-34019-00	223-34019-00
Element plug	223-34020-00	223-34020-00	223-34020-00	223-34020-00	223-34020-00

(LWD) = Low Watt Density

▲ For 12" Diameter tanks and above.

▲▲ For 14" Diameter tanks and above.

^ Element gaskets should be ordered with elements.

**Heating Elements (Incoloy) for:
Residential Series (RE)
Light Duty (LE) Commercial Series
Medium Duty (E32) Commercial Series
Commercial (MII) Series**

Wattage	120 Volt	208 Volt	240 Volt	277 Volt	380 Volt	415 Volt	480 Volt	600 Volt
1000W ▲	N/A	220-42545-13	220-42547-10	N/A	N/A	N/A	N/A	N/A
1250W ▲	N/A	N/A	N/A	N/A	N/A	N/A	N/A	N/A
1500W ▲	220-42541-02	220-42545-02	220-42545-13	220-42547-10	220-42551-12	220-42551-11	220-42553-09	N/A
1500W (LWD)▲	N/A	N/A	N/A	N/A	N/A	N/A	N/A	N/A
2000W ▲	N/A	220-42545-14	220-42545-02	220-42547-07	220-42549-04	220-42551-12	220-42553-01	N/A
2500W ▲	N/A	220-42545-11	220-42545-14	220-42547-11	220-42551-13	220-42549-04	220-42553-10	N/A
3000W ▲	N/A	220-42545-12	220-42545-15	220-42547-08	220-42551-10	220-42551-13	220-42553-08	N/A
3500W ▲▲	N/A	220-51328-07	220-42545-11	N/A	220-42551-14	220-42551-10	N/A	N/A
3800W ▲▲	N/A	N/A	220-42547-15	N/A	N/A	N/A	N/A	N/A
4000W ▲▲	N/A	220-42545-17	220-42545-12	220-42547-03	220-42551-16	220-42551-14	220-42553-03	N/A
4500W ▲▲	N/A	220-42545-19	220-51328-07	220-42547-12	220-42551-17	220-42551-15	220-42553-11	N/A
4500W (LWD) ▲▲	N/A	N/A	N/A	N/A	N/A	N/A	N/A	N/A
5000W ▲▲	N/A	220-42543-04	220-42545-18	220-42547-15	220-42551-18	220-42551-16	220-42553-12	N/A
5500W ▲▲	N/A	220-42543-05	220-42545-17	220-42547-13	220-42549-06	220-42551-17	220-42553-13	N/A
6000W ▲▲	N/A	220-42543-06	220-42545-19	220-42547-14	220-42549-05	220-42551-18	220-42553-14	N/A
Element gasket ^	223-34019-00	223-34019-00	223-34019-00	223-34019-00	223-34019-00	223-34019-00	223-34019-00	223-34019-00
Element plug	223-34020-00	223-34020-00	223-34020-00	223-34020-00	223-34020-00	223-34020-00	223-34020-00	223-34020-00

(LWD) = Low Watt Density

For bagged elements that include gasket, change part number prefix to 265- (example: 265-42541-02).

Element wrench *** 265-35897-12

*** For use with residential, LE, LD, E32, and MII series heating elements only. Not for use with commercial "A" series heating elements.

▲ For 12" diameter tanks and above.

▲▲ For 14" diameter tanks and above.

^ Element gaskets should be ordered with elements.



BRADFORD WHITE®

W A T E R H E A T E R S

Ambler, PA

For U.S. and Canada field service,
contact your professional installer or
local Bradford White sales representative.

Sales/800-523-2931

Technical Support/800-334-3393
Email/techserv@bradfordwhite.com

Warranty/800-531-2111
Email/warranty@bradfordwhite.com

Service Parts/800-538-2020
Email/Parts@bradfordwhite.com

International:
international@bradfordwhite.com



BRADFORD WHITE™

CANADA

Halton Hills, Ontario, Canada

Sales & Technical Support/866-690-0961
905-203-0600

Fax/905-636-0666

Email

Warranty/bwccwarranty@bradfordwhite.com
Technical Support/BWCCTech@bradfordwhite.com
Parts/orders@bradfordwhitecanada.com
Orders/ca.orders@bradfordwhite.com

www.bradfordwhite.com