

Brute® XTR



Hydronic Boiler

BNT2H Hydronic Boiler

Indoor Sizes 399-1500



Date:

Project #:

Engineer:

Prepared By:

Bid Date:

Submittal Data

Project Name:

Location:

Contractor:

Standard Features

- High condensing efficiency
- Stainless steel heat exchanger with welded construction
- ASME 160psi (1104Pa) working pressure heat exchanger
- ASME "H" stamp
- 75psi (517kPa) ASME rated pressure relief valve
- Modulation down to 10% of full fire (10:1 turndown)
- Low NOx system exceeds the most stringent regulations for air quality
- Indoor construction with optional outdoor kit
- Top water and gas connections
- Optional pump (sized to model) included for field installation
- Sealed combustion chamber
- Pre-mix stainless steel burner
- Sophisticated air/gas system allows for consistent combustion control
- Horizontal or vertical direct vent
- Certified for Category II & IV vent
- Category IV vent & air pipe lengths of up to 150 equivalent feet (each)
- Electronic PID modulating control with large touch screen user interface and color display
- Controller cascades with up to eight Brute XTR units
- Modbus RTU & BACnet MSTP on board
- Multiple pump control for boiler pump, system pump, and DHW pump, each with delay
- Direct spark ignition
- Indirect water heater priority
- Outdoor temp sensor
- Alarm output
- Accepts external (4-20mA or 0-10VDC) modulation signal
- On/Off toggle switch
- Top and rear service panels
- Built-in condensate trap
- Water flow switch
- Vent temperature cutoff
- Air filter
- Temperature & pressure gauge
- Drain valve
- Manual reset high limit
- Auto reset high limit
- Burner sight glass
- Zero clearance to combustibles
- 10-year limited hx warranty

Boiler Data

Number of Units

Fuel

 Natural Gas

Construction

- Standard
 ASME CSD-1

Options

- Pump
 Low Water Cutoff

Alternate PRVs

- 75 psi pressure relief valve (std)
 30 psi pressure relief valve
 50 psi pressure relief valve
 60 psi pressure relief valve
 125 psi pressure relief valve
 150 psi pressure relief valve



Accessories for Field Mounting

- Outdoor kit
 - Outdoor pump housing kit
 - CSD-1 kit (includes LWCO, gas pressure switches, display, control)
 - Pump
 - Pump contactor
 - Low water cut-off
 - High & low gas pressure switches
 - Additional auto & manual reset high limits
 - Gateway for BACnet IP
 - Gateway for LonWorks
 - Alarm bell with silence switch
 - Condensate neutralizer
 - Condensate neutralizer with pump
- For 399-500 models:
- Flush-mount vent terminal, 4"
 - PVC concentric termination kit
 - CPVC concentric termination kit

Sizing Data

Model	Min Input Rate		Max Input Rate		Min Output Rate		Max Output Rate		AHRI Certified	
	MBH	kW	MBH	kW	MBH	kW	MBH	kW	Thermal Efficiency %	Combustion Efficiency %
	<input type="checkbox"/> 399	39.9	11.7	399	117	38.6	11.3	386	113	96.7%
<input type="checkbox"/> 500	50.0	14.7	500	147	48.3	14.2	483	142	96.6%	98.4%
<input type="checkbox"/> 650	65.0	19.0	650	191	62.7	18.4	627	184	96.5%	98.2%
<input type="checkbox"/> 800	80.0	23.4	800	235	77.1	22.6	771	226	96.4%	98.0%
<input type="checkbox"/> 999	99.9	29.3	999	293	96.2	28.2	962	282	96.3%	97.7%
<input type="checkbox"/> 1500	150.0	44.0	1500	440	144.0	42.2	1440	422	96.0%	97.0%

Model	Product Weight		Operating Weight		Shipping Weight		Water Content	
	lbs	kg	lbs	kg	lbs	kg	gal	l
399	391	178	427	194	508	231	4.4	16.5
500	401	182	441	200	518	235	4.8	18.1
650	471	214	525	238	597	271	6.4	24.4
800	492	224	554	252	618	281	7.4	28.2
999	542	246	616	280	679	309	8.9	33.9
1500	620	282	714	325	757	344	11.3	43.0

Clearances

	Clearance to Combustibles		Suggested Service Clearance	
	Inches	cm	Inches	cm
Front	0	0	24	61
Back	0	0	24	61
Left	0	0	0	0
Right	0	0	0	0
Top	0	0	24	61

Venting System

Model	Air Intake			Vent			
	Diameter (in)	Min. Equivalent* Length (ft)	Max. Equivalent* Length (ft)	Category IV Diameter (in)	Category IV Min. Equivalent* Length (ft)	Category IV Max. Equivalent* Length (ft)	Typical** Category II Diameter (in)
399	4	0	150	4	10	150	12
500	4	0	150	4	10	150	12
650	6	0	150	6	10	150	12
800	6	0	150	6	10	150	12
999	6	0	150	6	10	150	12
1500	8	0	150	8	10	150	12

*Equivalent Length: Add 5 feet for each 90° elbow up to the first 6. If more than 6 are needed in either the vent or air intake, or any 45° elbows are required, see the table below for the additional length to be added.

**Category II vent pipe size may vary. Draft must remain between -0.10" and -0.001" w.c.

Diameter (in)	Elbow Equivalent Lengths (ft)					
	Air Intake			Vent		
	90° Elbows (up to 6)	90° Elbows (after first 6)	45° Elbows	90° Elbows (up to 6)	90° Elbows (after first 6)	45° Elbows
4	5	5	3	5	5	3
6	5	10	5	5	10	5
8	5	15	8	5	15	8

Water Flow Requirements

Model	Temperature Rise (°F)									
	20		30		40		50		60	
	Flow gpm	H/L ft	Flow gpm	H/L ft	Flow gpm	H/L ft	Flow gpm	H/L ft	Flow gpm	H/L ft
399	38	10.8	26	4.8	19	2.7	15	1.8	13	1.2
500	48	12.0	32	5.3	24	2.9	19	1.9	16	1.3
650	62	12.2	42	5.4	31	3.0	25	1.9	21	1.3
800	77	13.3	51	5.9	38	3.3	31	2.2	26	1.5
999	96	15.0	64	6.8	48	3.9	38	2.5	32	1.8
1500	144	35.2	96	15.7	72	8.8	58	5.7	48	4.0

Model	Temperature Rise (°C)									
	11		17		22		28		33	
	Flow lpm	H/L m	Flow lpm	H/L m	Flow lpm	H/L m	Flow lpm	H/L m	Flow lpm	H/L m
399	145	3.3	97	1.5	72	0.8	58	0.5	48	0.4
500	182	3.7	121	1.6	91	0.9	73	0.6	61	0.4
650	236	3.7	157	1.6	118	0.9	94	0.6	79	0.4
800	291	4.1	194	1.8	145	1.0	116	0.7	97	0.5
999	363	4.6	242	2.1	182	1.2	145	0.8	121	0.5
1500	545	10.7	363	4.8	273	2.7	218	1.7	182	1.2

Electrical Data

Boiler Only				
Model	Voltage	FLA	MCA	MOP
399	120	2.8	3.5	15
500	120	3.1	3.9	15
650	120	3.1	3.9	15
800	120	3.2	4.0	15
999	120	4.2	5.3	15
1500	120	5.4	6.8	15

Boiler and Pump				
Model	Voltage	FLA	MCA	MOP
399	120	4.7	5.9	15
500	120	5.0	6.3	15
650	120	6.7	8.4	15
800	120	6.8	8.5	15
999	120	10.3	12.9	20
1500*	120	-	-	-

Pump Only				
Model	Voltage	FLA	MCA	MOP
399	120	1.9	2.4	15
500	120	1.9	2.4	15
650	120	3.6	4.5	15
800	120	3.6	4.5	15
999	120	6.1	7.6	15
1500	120	8.8	11.0	15

FLA = Full Load Amperage
MCA = Minimum Circuit Ampacity
MOP = Maximum Over-current Protection

*On 1500 models with factory supplied pumps, it is necessary to use two circuits; one to supply power for the boiler or water heater and another to power the pump.

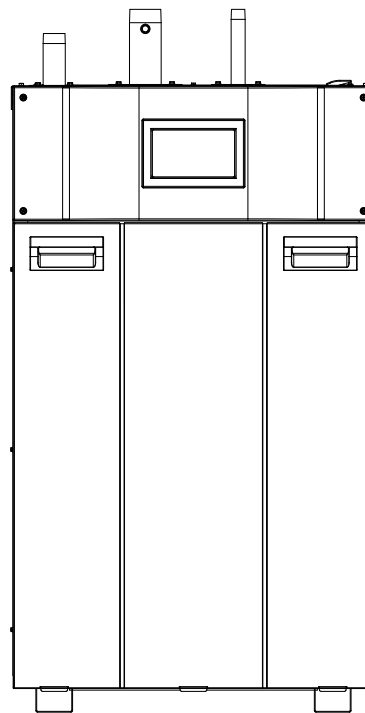

FRONT VIEW

**Dimensional
Data**

Model	Dimensions (Inches)								
	A	B	C	D	E	Gas Conn.	Water Conn.	Air Inlet	Vent
399	47-1/4	41-1/2	23-1/4	12	5	1	2	4	4
500	47-1/4	41-1/2	24-1/2	13-1/2	5	1	2	4	4
650	54-1/4	48-1/2	31-1/4	17-3/4	3-1/4	1-1/4	2	6	6
800	54-1/4	48-1/2	34	20-3/4	3-1/4	1-1/4	2	6	6
999	57-3/4	52	35	25-1/2	4	1-1/2	2-1/2	6	6
1500	66-3/4	61	42-1/2	33	4	1-1/2	2-1/2	8	8

Model	Dimensions (cm)				
	A	B	C	D	E
399	120	105	59	31	13
500	120	105	62	34	13
650	138	123	79	45	8
800	138	123	86	53	8
999	147	132	89	65	10
1500	169	155	108	84	10

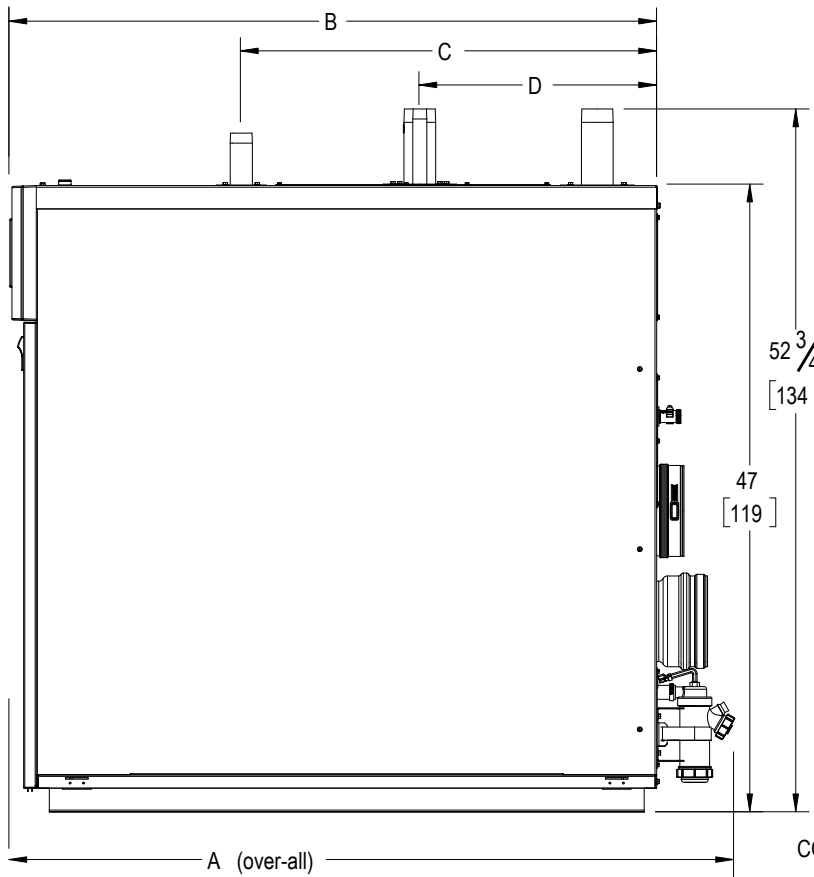

RIGHT SIDE VIEW

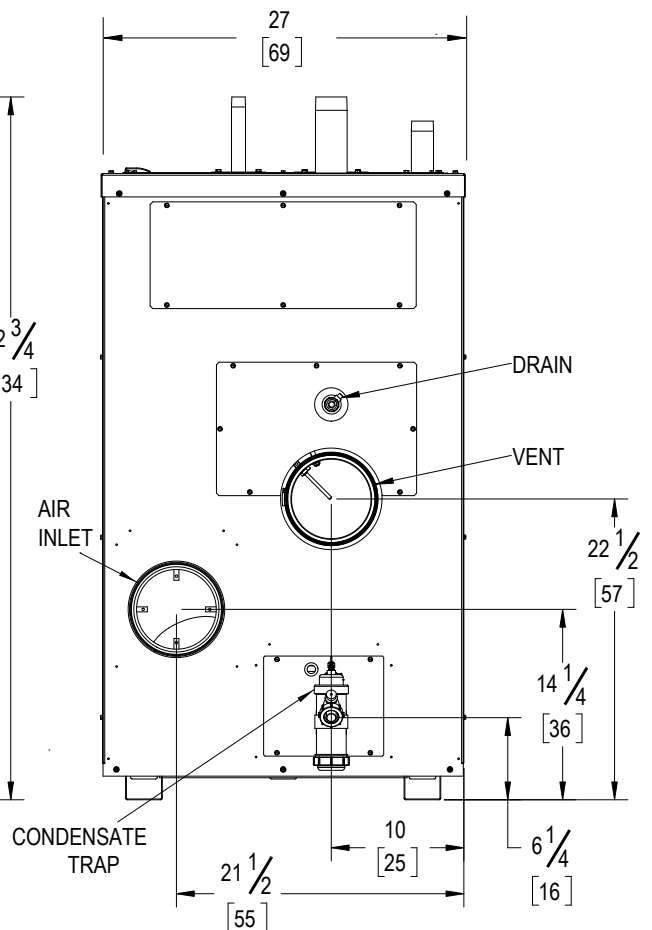

BACK VIEW

Dimensional
Data (continued)

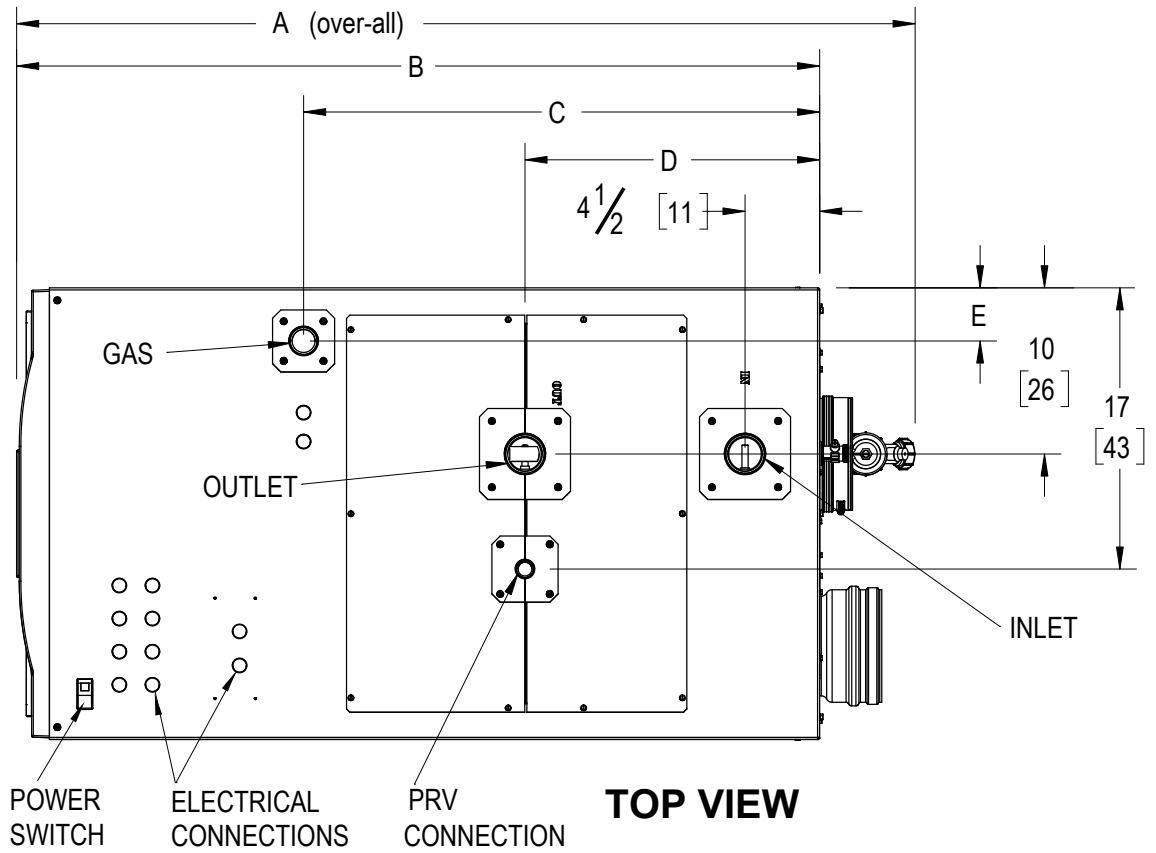

Bradford White Corporation reserves the right to change specifications, components, features, or to discontinue products without notice.